

OFF-GRID SOLAR POWER MADE SIMPLE

A Simple Guide to Building and Installing Solar Power Panels
for Homes, Cabins and Vehicles.

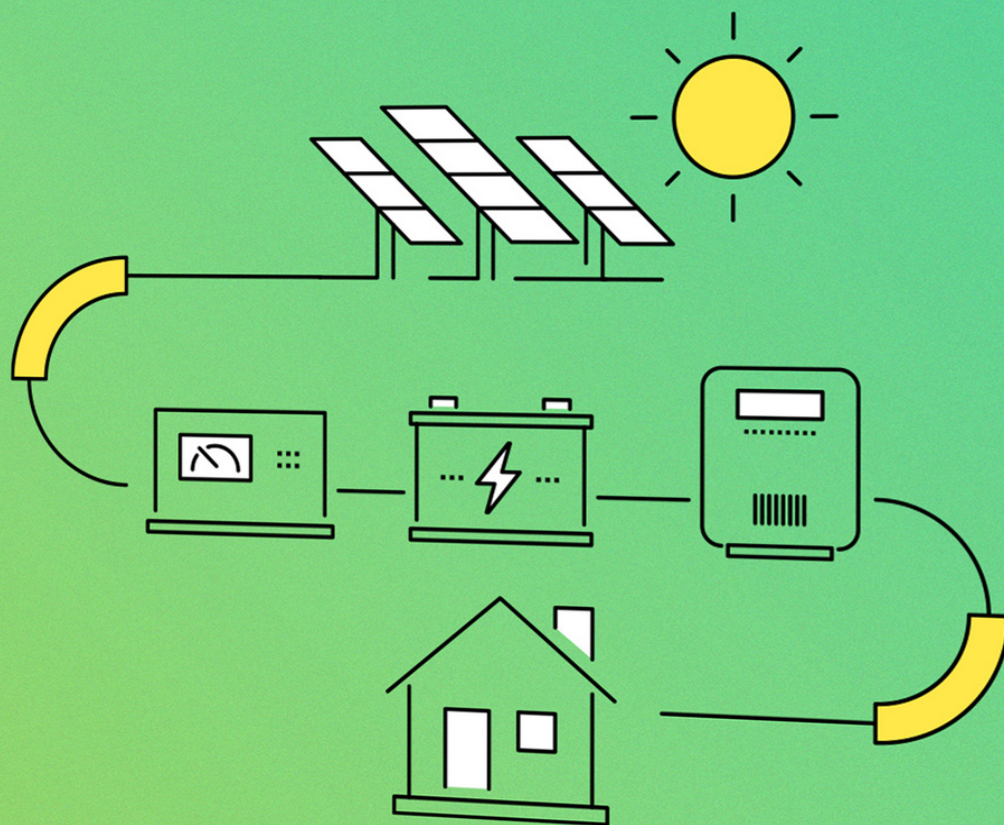

CHRIS NEWAK

OFF-GRID SOLAR POWER MADE SIMPLE

A Simple Guide to Building and Installing Solar Power Panels
for Homes, Cabins and Vehicles.

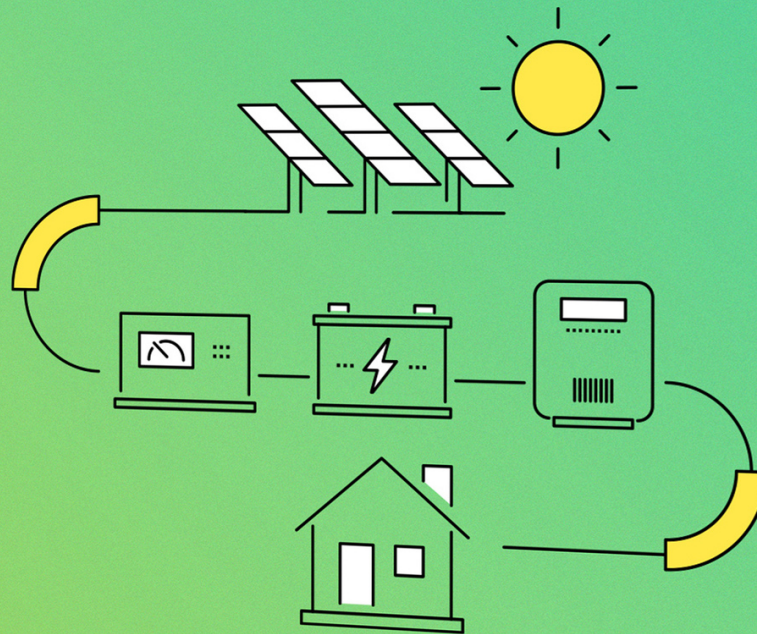

CHRIS NEWAK

OFF-GRID SOLAR POWER MADE SIMPLE

*A Simple Guide to Building and Installing Solar
Power Panels for Homes, Cabins and Vehicles.*

**© Copyright 2020 by Chris Newak
All rights reserved.**

This document is geared towards providing exact and reliable information with regards to the topic and issue covered. The publication is sold with the idea that the publisher is not required to render accounting, officially permitted, or otherwise, qualified services. If advice is necessary, legal or professional, a practiced individual in the profession should be ordered.

- From a Declaration of Principles which was accepted and approved equally by a Committee of the American Bar Association and a Committee of Publishers and Associations.

In no way is it legal to reproduce, duplicate, or transmit any part of this document in either electronic means or in printed format. Recording of this publication is strictly prohibited and any storage of this document is not allowed unless with written permission from the publisher. All rights reserved.

The information provided herein is stated to be truthful and consistent, in that any liability, in terms of inattention or otherwise, by any usage or abuse of any policies, processes, or directions contained within is the solitary and utter responsibility of the recipient reader. Under no circumstances will any legal responsibility or blame be held against the publisher for any reparation, damages, or monetary loss due to the information herein, either directly or indirectly.

Respective authors own all copyrights not held by the publisher.

The information herein is offered for informational purposes solely, and is universal as so. The presentation of the information is without contract or any type of guarantee assurance. The trademarks that are used are without any consent, and the publication of the trademark is without permission or backing by the trademark owner. All trademarks and brands within this book are for clarifying purposes only and are the owned by the owners themselves, not affiliated with this document

TABLE OF CONTENTS

INTRODUCTION

[How are Electricity-generating Turbines Used?](#)

[When do you Calculate Electricity?](#)

THE SCIENCE OF ELECTRICITY

[STATIC ELECTRICITY](#)

[MAGNETS AND ELECTRICITY](#)

[BATTERIES PRODUCE ELECTRICITY](#)

[HOW ELECTRICITY IS GENERATED](#)

[MEASURING ELECTRICITY](#)

[THE FUNDAMENTAL OF AN ELECTRICAL CIRCUIT](#)

SELECTING SOLAR POWER SYSTEM COMPONENTS

[Solar Panels](#)

[Overview and Appearance of Monocrystalline](#)

[Overview and Appearance of Polycrystalline or Multicrystalline](#)

[Advantages of Monocrystalline](#)

[Advantages](#)

[SOLAR CHARGE CONTROLLER](#)

[THE SOLAR CHARGES CONTROLLER ARE](#)

[THE ENERGY STORAGE TECHNOLOGY](#)

[How Long Will Batteries with Solar Energy Last?](#)

[What is the safest solar battery?](#)

[Lead-acid Batteries](#)

[Lithium-ion](#)

[Saltwater](#)

[SELECTING AN INVERTER](#)

[How to pick the inverter for your needs](#)

[Mobile Inverter](#)

[On-Grid Without Backup](#)

[Larger Systems](#)

HOW TO INSTALL A SOLAR POWER SYSTEM

[Some Steps to Help You:](#)

[Using Them or Lose Them](#)

[ADDITIONAL SUPPORT](#)

MORE TIPS ON INSTALLING THE SOLAR SYSTEM

[Typical Solar Power System Payback Time](#)

[Do you Need these Batteries?](#)

[How do you Expect your Device to Pay? Economic Comprehension](#)

[DIY Solar: What is it?](#)

[What are DIY Solar's Pros and Cons?](#)

[Learn how to Make your Solar Panels](#)

[Tips on Building Solar Panels and Mounting Them](#)

[Solar Panels & Solar System Installation](#)

[Plugs or Panels?](#)

APPLICATION OF SOLAR POWER SYSTEM

[Solar Energy Benefits](#)

[Tax Benefit Qualification](#)

[Solar Energy is Applicable All Over the World](#)

[Increased Grid Protection](#)

[Work Creation](#)

APPLICATIONS IN HOMES

[Solar Water Heaters](#)

[Solar Outdoor Lights](#)

[Solar Cookers](#)

[Solar Buildings Heating](#)

APPLICATION IN VEHICLES

APPLICATION IN INDUSTRIES

SOLAR POWER FOR TELECOMMUNICATION NETWORKS

APPLICATION IN BOATS

APPLICATION IN CABINS

MAINTENANCE OF A SOLAR POWER SYSTEM

[Solar Power Warranties](#)

MONITORING YOUR SOLAR POWER SYSTEM

CONCLUSION

[Repairing and Replacing Solar Panels](#)

INTRODUCTION

Electricity is a type of power made up of electron flows. It is a secondary source of energy produced by the combustion from other energy sources, such as oil, natural gas, coal, nuclear power, and others. This is a vital part of the climate. The power of free-flowing water such as waterfalls or rivers can be used as a source for generating electricity through the use of mechanisms.

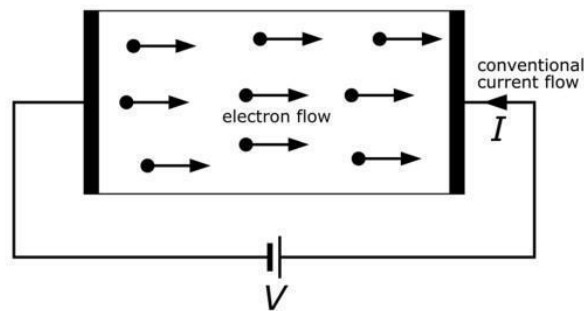

Power is an energy source. Every matter consists of atoms, and there is an atom called a nucleus. The nucleus consists of charged particles called protons and uncharged neutrons. The center of an atom is surrounded by particles called electrons, which are negatively charged. The electron's negative load is identical to a proton's positive charge, and usually, the electron count is equal to the proton count. If an external force disturbs the equilibrium force between protons and electrons, an atom can gain or lose an electron. The free movement of such electrons becomes an electrical current if electrons are "missing" in an atom.

Electricity is one of the very commonly used sources of energy and is a fundamental feature of nature. The extraction of electricity from other sources of energy, such as coal, natural gas, and oil, as well as nuclear energy and other natural resources, called primary sources, gives us a secondary source of renewable energy. Together with waterfalls (a key mechanical energy source), many towns were built to enable water wheels to operate. Houses were lit up with gas lamps, the food was frozen in ice-

boxes, and the rooms were warmed by wood-fires and fire stoves before electricity's generation just over 100 years ago. The concepts of electricity have slowly been recognized, beginning with Benjamin Franklin's experiment with a stormy kite one night in Philadelphia. In the mid-1800s, the invention of the electric bulb changed everybody's lives. Electricity was used in outdoor lighting in arc lights before 1879. The invention of the light bulb uses electricity to carry light into our homes.

What is the Function of a Transformer?

George Westinghouse and William Stanley had designed a transformer system to address the question of transmitting energy over long distances. The energy can be distributed effectively over long distances by the transformer. This allowed households and businesses far from the generation plant to be provided with electricity.



While this is very important in our everyday lives, most of us avoid thinking about life without these resources. We prefer to take energy as a matter of nature, like air and water. We use electricity for our daily activities, from lighting and heating to cooling and running televisions and computers. Each day, we use electricity. Electricity is a controllable and convenient energy form used for heat, light, and power applications.

An electric power system is now set up in the United States (U.S.) to ensure that ample energy supplies are generated at any one time to satisfy all demand requirements.

Why do you Produce Electricity?

An electric generator is an electrical power conversion device. The cycle depends on the relationship between electricity and magnetism. When a cable or some other electrically compatible object crosses a magnetic field, an electric current takes place in the cable. The broad electric power generators are equipped with a steady conductor. A magnet is mounted inside a secure conductive ring wrapped in a long, continual wire at the end of a revolving shaft. As the magnet rotates, each part of the wire produces a slight electric current. A small, separate electric conductor constitutes each wire section. All the small currents of each segment add up to one big current. This current is used for electricity.

How are Electricity-generating Turbines Used?

An electric power plant uses an electric generator, a turbine, a motor, a water wheel, or a similar system to drive a generator or an electricity converter. The most popular methods for producing electricity include steam turbines, internal combustion engines, gas combustion turbines, water turbines, and wind turbines.

Most power is generated in steam turbines in the United States. The kinetic energy of a fluid (liquid or gas) is converted into mechanical energy by a turbine. Steam turbines have several blades on a shaft to which steam is driven, and the shaft connected to the generator rotates. The fuel is burned in a furnace to heat water in a boiler to produce steam in a fossil-fueled steam turbine.

Coal, gasoline, and natural gas are burned to heat water in a large furnace to create vapor that drives the blades of a turbine in turn. Are you aware that coal is the primary power source in the United States used for producing electricity? In 1998, the country used coal to produce power in more than half (52-percent) of its 3,62 trillion kilowatts of power.

Natural gas may also be burnt to create hot combustion gases, directly passing through a turbine that spins the turbine blades to generate electricity, as well as to heat water into steam. If the demand for energy is high, gas turbines are widely used. 15% of electricity in the country was powered by natural gas in 1998.

Petroleum can also be used to move a turbine by using steam. The petroleum product used in electric power plants to produce steam is also the residual fuel oil derived from crude oil. In 1998, less than 3-percent (3%) of all power produced in U.S. power plants was made using petroleum.

Nuclear power is a mechanism by which a process called nuclear fission creates steam from boiling water. A reactor includes a nuclear core fuel, mainly enriched uranium, in a nuclear power plant. When neutrons strike uranium fuel atoms, heat is released, and more neutrons are emitted. These other neutrons will hit more uranium atoms under controlled conditions, break more atoms, etc. This may lead to ongoing fission, forming a chain reaction that releases heat. The heat is used to transform water into steam, which spins an electricity-producing turbine. In 2015, 19.47-percent of all the country's electricity was generated using nuclear power.

As of 2013, 6.8% of the U.S. electricity supply was made up of hydropower. It is used to move a turbine attached to a generator by flowing water. Most of the hydroelectric systems generating electricity have two basic forms. The first method accumulates water through the use of dams in reservoirs. The water falls through a tube called a penstock and forces the turbine blades to fuel the generator. The forcefulness of the current in the river (instead of the falling water) is applied to the turbine blades to generate electricity in the second phase, known as run-off.

The geothermal power and other generation sources come from under the earth's surface heat energy. In some parts of the world, magma flows near the earth's surface to heat underground water into steam, which can be exploited to be used in steam turbines. In some parts, magma can also be used in certain cases. As of 2013, this source of energy generates less than 1-percent of the country's electricity, as stated in a U.S. assessment. Energy information administration shows that nine Western countries can generate

sufficient electricity to supply 20-percent of the energy requirements of the country using this method.

Solar energy comes from the sun's energy. However, the energy of the sun is not fully available and is widely dispersed. Historically, processes used to produce energy from the sun have been more expensive than the use of conventional fossil fuels. Photovoltaic transmission directly generates electric power in a photovoltaic (solar) cell from the light of the sun. Solar thermal power generators use sunlight to produce steam for driving turbines. Solar energy supplies in the country accounted for less than 1-percent in 2015.

The energy found in the wind is transformed into electricity by wind power. Like the sun, wind power is typically an expensive form of electricity output. In 2014, approximately 4.44% of the electricity produced with this method in the nation was used. A wind turbine is like a regular windmill.

Some other sources of energy for the production of electricity are biomass (wood, municipal solid waste), and agricultural waste such as maize cobs and wheat straw. The sources substitute in the boiler for fossil fuels. Typical use in modern steam power plants is the burning of wood and waste. In 2015, the electricity produced by biomass accounted for 1.57% in the U.S.

The created electricity flows along a cable into a transformer that switches from low-voltage to high-voltage electricity. The effective use of high-voltage allows electricity to travel long distances. The electricity is transported to a substation via transmission lines. Substances are fitted with transformers that transform high voltage electricity into less power. Distribution lines convey electricity from the substation to houses, offices, and plants that need electricity of low-voltage.

When do you Calculate Electricity?

Power units called watts are used to measure electricity. The name was awarded to James Watt, the steam engine inventor. One watt is very little electricity. It takes about 750 watts to reach power for one hour. A thousand watts makes one kilowatt (kW). The energy of 1 000 watts working for one-hour is equivalent to one kilowatt-hour (kWh). The amount of energy produced or expended by a power plant is measured in kilowatt-hours

(kWh). The number of kW needed by the number of operating hours is multiplied to calculate kilowatt-hours.

$$1000 \text{ Watts} \times 1 \text{ hour} = 1 \text{ kWh}$$

Of course, any mention of electricity's history would include lightning. Lightning is a large electric discharge that is created during storms.

When you drag your feet over a carpet, cumulonimbus clouds are filled with electricity, not unlike when electricity loads. And if you hit an unladen object and release a "shock," a cloud gets close enough to release the accumulated static energy .

Electric power is produced typically by electric generators that drive alternate sources of fuel such as steam, fossil fuel, nuclear heat, or water or wind-derived energy.

Given that electricity cannot be stored conveniently in large amounts to satisfy national demands, it has to be precisely supplied at specific points. This requires power companies to use their areas of operation to pay careful attention to the peaks and valleys. If not, then too much power is wasted, and too little causes a whole new range of issues, such as blackouts and brownouts. This may lead to serious harm to equipment.

Energy is a charging flow. This is a sub-source of energy that implies that we receive it through the conversion of other sources of energy, such as natural gas, oil, nuclear power, etc., called primary sources. The energy sources that we use to generate electricity can be green or not, but electricity is neither sustainable nor green in of itself.

Nikola Tesla pioneered electricity generation, transmission, and use in the late 1800s, with the use of alternating current (AC), which is transmitted much longer than direct current.

Tesla's inventions brought electricity into our homes and the energy industry.

THE SCIENCE OF ELECTRICITY

We need to understand atoms to understand how electricity moves from one atom to another—all the atoms of the universe — all the planets, each tree, each object. The body of men consists of atoms.

Atoms are the universe's building blocks. Atoms are so small that millions fit on a pin's head.

Even smaller particles are made of atoms. The nucleus is seen as the center of an atom. It consists of particles such as neutrons or protons. There are small protons and neutrons, but there are far fewer electrons. Electrons spin around the heart in shells, very far from the heart. The atom could be the size of the Empire State Building if the center were the size of a tennis ball. Atoms are essentially empty space. If you were able to see an atom, it would look a little like a small core of balls with huge transparent bubbles (or coats). The electrons are continually spinning and traveling on the surface of the bubbles so that they remain as far away as possible.

An electrical force traps electrons in their shells. The atoms are attracted to each other by protons and electrons. Both of them have an electrical charge. An electric charge is a particle force. Protons are charged positively (+), and electrons are charged negatively (-). The protons' positive charge is equal to the electrons' negative charge. Opposite charges are equally desirable. It has the same number of protons and electrons when an atom is in equilibrium. The neutrons are free and can differ in number. The number of protons in an atom decides what sort of atom it is. One element is a substance, all the atoms being the same (all known elements are seen on the periodic table). For starters, every hydrogen atom has a single proton and an electron without neutrons. There are six protons, six electrons, and six neutrons in every atom of carbon. The number of protons determines the element. Electrons remain in precision shells, usually at a constant distance from the nucleus. There are two electrons in the shell closest to the center. Up to eight will carry the next shell. Some atoms with many protons can contain as many as seven shells of electrons. The outer shells contain many more.

The electrons attract the protons in the shells closest to the nucleus. The electrons in the outermost shells often don't. They can be forced out of their orbits. The use of force will cause them to switch from one nucleus to the next. Electricity is made of such moving electrons.

STATIC ELECTRICITY

In the universe, electricity has always existed. It's lightning. It's electrons that pass or leap from a cloud into the earth. Have you ever experienced a shock after crossing a carpet when you hit an object? From this body shoots a stream of electrons to you. Have you ever straightened your hair by rubbing a balloon against it? This is called static electricity. If so, several electrons are rubbed off the surface. The electrons have transferred from the balloon into your head. By going to the ends of the hairs, they tried to get away from each other.

You pulled and shifted your hair — they repelled each other. Just as counterfeit charges draw one another, charges repel one another.

MAGNETS AND ELECTRICITY

A small magnetic field is generated by moving the electrons around the nucleus of an atom.

The majority of artifacts are not magnetic, but atoms are arranged for electrons to rotate and cancel each other in different random directions.

The magnets are different. The molecules in the magnets are structured so that electrons pass in the same direction. This atomic arrangement produces two pole sizes in an image: a pole in the North and a pole in the

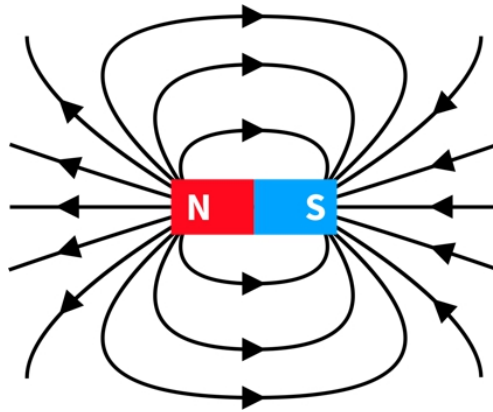

Both North (N) and South (S) poles are labeled on a magnet. The magnet force moves from the North poles to the South poles in a vacuum. A magnetic field around a magnet is formed .

Have you ever touched two magnets together? They don't move. They repel each other as you try to force the South poles together. They even repel each other by two North poles.

Switch one magnet, and they are drawn together by the north (N) and south (S) poles. The magnets have a strong force as protons and electrons attract opposites.

The magnets may use these unique characteristics to generate electricity. Magnetic pulls and electrons will transfer magnetic fields. Other metals, such as copper, have loosely retained electrons. By shifting the magnets,

you can move them out of their shells. For electric generators, magnets and wires are used together.

BATTERIES PRODUCE ELECTRICITY

A battery produces energy in a chemical solution using two separate metals. A chemical reaction between metals and chemicals releases in one metal more electrons than in the other. One end of the battery is connected to one wire; the other end is connected to the other wire.



A positive charge develops at the end that liberates more electrons, and a negative charge develops in the other. When a wire is attached to the other end of the battery, the electrons pass through the wire to equilibrate the electric charge. A load is a functioning or performing tool. If a load – such as an electric bulb – is put along the wire, power will operate as the wire flows. In the above image, electrons flow from the battery's negative end to the wire. The power flows into the light bulb through the wire and back into the battery.

Electricity travels back in closed loops or circuits (from the word circle). Electricity travels in CIRCUIT. Before the electrons can travel, it must have an entire path. The electrons can't move while a circuit is open.

We close a circuit when we turn on a light switch. Power runs through the light and back into the wire from the electrical wire. When we turn off the switch, the circuit is opened. There is no surge of energy. When a light switch is triggered, the energy in the lamp is transmitted via a short cable. The wire gets very hot. It lights up the gas in the bulb.

When the small wire has snapped while the lamp is burned out. The road to the bulb has gone.

If we trigger a camera, power flows through the wires and creates images and sounds. Electricity also powers engines — in washers or mixers. Electricity is doing much work. Every day, we use it many times.

HOW ELECTRICITY IS GENERATED

Mechanical energy transformation is done in the system generator. The cycle is based on magnetism-electricity relationships. In 1831, Faraday found that electricity flows through the wire as a magnet is placed within a metal bucket.



In a power station, a modern generator uses an electromagnet — an electricity-driven magnet — not a standard magnet. The generator has several isolated wire coils forming a fixed cylinder. A rotative electromagnetic shaft surrounds this cylinder.

When the electromagnetic shaft rotates, a small electrical current is induced in every part of the wire. A small, separate electric conductor becomes each section of the wire. There is one major current with the tiny currents of individual segments combined. This current is the electricity transmitted to the customer from the power utility plant .

A power plant uses either a turbine, an engine, a water wheel, or another machine of the same kind for power generators or mechanical or chemical energy converting to power generation. The most popular methods of producing electricity are steam turbines, internal combustion engines, gas combustion turbines, water turbines, and wind turbines. Many power plants have a capacity of about 35%. In other words, only 35 units are converted

into usable electrical energy for each 100 power units produced in one facility. Most electricity is generated in steam turbines in the United States. The kinetic energy of a constantly moving fluid (liquid or gas) is converted into mechanical energy by a turbine. Steam turbines have several blades mounted on a shaft, forcing steam to turn the shaft connected to the generator. The fuel is burned in a fossil steam turbine in a furnace to produce steam to heat the fuel in the boiler. Coal, oil, and natural gas are consumed in large heating furnaces to generate steam, which pushes on the turbine blades.

Natural gas may also be combusted in hot combustion gases, which pass through a turbine directly and spin on the blades of the turbine for electricity generation, as well as heating water for steam. When the use of energy sources is in high demand, gas turbines are widely used. In 2007, the country produced 21.6-percent of its electricity via gas.

The heat energy reached under the surface of the Earth creates geothermal energy. In certain areas of the world, heat is brought close to Earth's surface, which can be heated to steam in underground water, which can be used in steam turbines. In 2007, less than 1% of the electricity produced in the country was by this source.

Wind power derives from the conversion of wind energy into electricity.

Wind power is a fast-growing source of energy but was supplying less than 1% of the nation's energy in 2007. A wind farm is like a conventional wind turbine.

There are several other sources of energy for electricity generation.

These sources substitute the boiler with fossil fuels. Typical use in conventional steam-electric facilities is steam from the burning of wood and waste. In the United States, biomass accounts for approximately 1-percent of electricity produced.

The use of high voltage can make the movement of electricity over long distances more efficient. For transmitting the electricity to a substation, transmission lines are used. Transformers that transform high tension electricity into low tension electricity are installed in substations.

Distribution lines often carry electricity from the substation to houses, offices, and plants that use low voltage power.

MEASURING ELECTRICITY

Power units or watts are used to calculate electricity. The name was given to honor James Watt, the steam engine inventor. One watt is very little electricity. Almost 750 watts would be required for one hour. One kilowatt is 1,000 watts. The output of 1000 watts operating for one hour equals a kilowatt-hour. The electricity generated by a power plant or used by a consumer is measured in kilowatts (kWh) over a while. By multiplying the number of kW actually needed by the number of hours of usage, kilowatt-hours shall be calculated.



You have, for example, used 200-watt-hours, or 0.2 kilowatt-hours, of electric power if you use a 40 watt light bulb five hours a day. One watt is a little electricity. Some devices only need a few Watts, and some devices need higher quantities. Tiny devices typically measure energy consumption in watts, and larger devices measure their electricity usage in kilowatts (kW) or 1000 watts.

Capacity to produce electricity, such as megawatts (MW) and gigawatts (GW), is also estimated over millions of kilowatts. One MW is 1 000 kW (or 1-million watts), and one GW is 1000 MW (or 1-billion watts).

In Watt-hours

In a Watt-hour (Wh), the energy use is equal to that of one Watt, which constantly fills or takes one hour from an electric circuit. Usually, kilowatt-hours (kWh) calculate the amount of electricity produced from a power plant or used by electricity customers. One kWh would be one kilowatt for

one hour. For instance, you have used an electric light bulb of 40 Watts (0.04 kW) in five hours, using 200 Wh or 0.2 kWh.

Utility companies calculate and track electricity use using meters. The electricity uses of the customers are calculated by meters, usually outside the customer's home, where the power line reaches the land. The electric energy use is calculated. During the past, all-electric meters were mechanical instruments that had to be read manually by a utility employee. Automated reader tools were finally made available. Such meters record the use of electricity from mechanical meters with an electronic signal regularly. Many utilities now use electronic smart meters to calculate electricity consumption in practice, providing wireless access to the meters' power usage data. In some smart meters, the energy consumption of individual devices can also be measured, and energy uses are remotely monitored.

Electricity is a source of power consisting of billions of electrons, just like a stream of water flowing through a channel. The electrical supply is the latest. Current wires, also called conductors, pass through. The wires are coated with an insulation layer that avoids shocks and ensures maximum power reaches its destination.

Depending on the type of system or whether it is in a wet or dry area, the type of isolation can differ. When several wires are connected together, you have a cord. Cables are packed in steel and often referred to as BX cables, with high-duty but flexible cabling. The cables are called ducts, instead of wires, when embedded in nonflexible steel tubing. The entire course of a current circuit is generally known as a circuit from beginning to end.

A circuit consists of three basic components: the source, or the place of origin, the way it flows, and the electric unit (the unit) through which it flows. In the fluorescent light bulb, there is a common type of circuit. A closed-circuit is called a fully working circuit. An open circuit (or broken) has been blocked to prevent the flow of electricity. If existing flows in an unforeseen trajectory due to a wire failure or some other reason, a short circuit occurs.

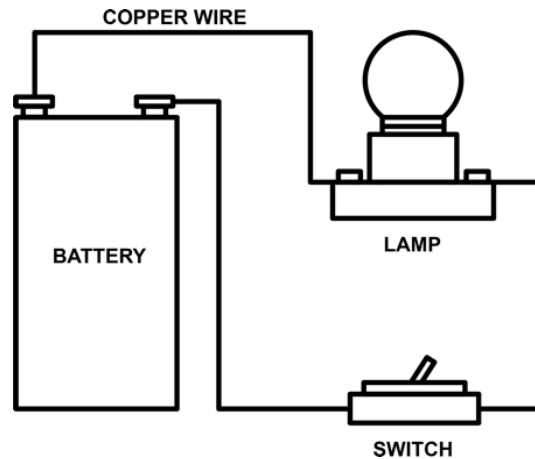

Short circuits are unreliable because they can cause damage with fire to other devices. Fortunately, certain monitoring systems are available to avoid short circuits. A fuse is a charging system that can interrupt an electro-circuit automatically if there is a surplus charge state. Both machines and humans are covered by the fuse. In a moment, more about them is that An electric switch is close to the breaker circuit. When it starts receiving higher electric power than its capacity, it automatically switches off.

The disruptor could be re-activated manually without damaging electric lines or equipment as the charge decreases. There are four fundamental concepts in the calculation of electric power, in addition to kilowatt-hours (kWh) and Kilovolt Amps. You need to know them as most kitchen appliances are classified according to the following terms (for production or energy efficiency).

Breakdown: This is a term for how a lot of electrical current passes through a circuit. Commonly known as an amp. A lightbulb of 100 watts, for example, requires 0.832 amps of power. The greater the diameter of an electric wire, the more amps it can hold safely so that the correct wire size for your needs can be calculated by a licensed electrician.

The National Electrical Code defines quality standards for cables. For example, the minimum size is # 14; for aluminum wire, # 12. In general, 15 amperes (a single-circuit breaker) or 30 amps (a double), the circuit breakers are often rated in amperes. The main electrical outlet in the home provides 15 amps for connecting appliances, lamps, etc. Electric shock can be triggered by just 0.02 volts. The letter "I" means amperes in electrical formulas.

Volt

The voltage is an electrical driving force pulling an ampere. The power to drive 1 amp electricity for 1 second could be a single volt. Popular voltages are 110-120 and 208-240 for appliances. This means the voltage needed to operate the device effectively; most devices have a minimum 120-volt requirement. The letter E shows volts in electric formulas.

Watt

The watt is the real energy output, the quantity of electricity in a circuit. One watt is equivalent to one amp of electricity at one-volt energy. Most electrical devices are measured in watts and volts as well. The letter W shows watts in electric formulas.

Ohm

This is a less well-known term; an ohm is an electrical resistance unit. It states whether a substance is a good electric power conductor or an insulator that limits electrical flow. Copper, silver, and drinking water are examples of conductors. The dry air, wood, rubbers, and distilled water are examples of insulators. The letter R (for "resistance") means ohms in electric formulas .

Why do these words need to be known? It might be appropriate to have an amp, volt, or watt to help you determine what devices you want to purchase, to test the efficiency of existing devices, or to detect whether a circuit is about to be overloaded when attached. You will now find a few simple ways to translate the data into the power metric you need to make a specific situation. Now you know the terminology. There are two ways to look for volts:

1. Watts: $E = W: I$
2. Amps: $E = I \times R$

There are two ways of locating amps. Or subtract amps by ohms.

You will find two methods to find volts:

1. Divide watts by amps: $E = W: I$
2. Or multiply amps by ohms: $E = I \times R$

There are two methods to find amps.

1. Divide volts by ohms: $I = E: R$
2. Or divide watts by volts: $I = W: E$

To find watts, multiply volts by amps:

$$W = E \times I$$

THE FUNDAMENTAL OF AN ELECTRICAL CIRCUIT

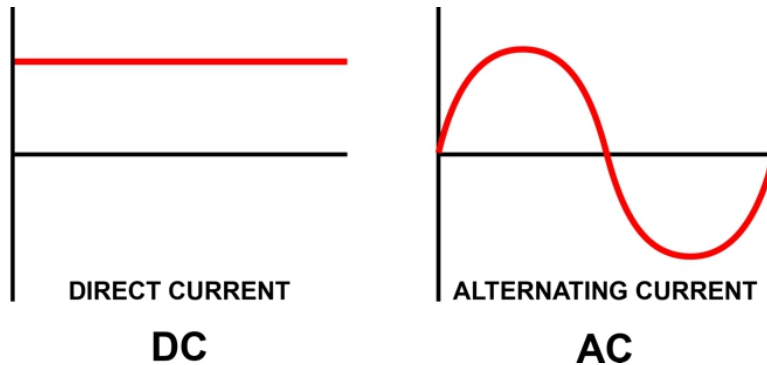

We're only going into AC and DC circuit theory, and a bit of history in general. Three key players in the electrical generation and transmission industries were active in the latter part of the 19th century. The principal proponent of direct power transmission was Thomas Edison, known as the "Menlo Park Magician" and adequately known for his invention of the electric bulb. The primary promoters of alternate current (AC) propagation were George Westinghouse and Nikola Tesla. This formative time for electrical generation and transmission has been reported as a "battle of currents." Edison has been depicted as the indefatigable inventor filing the United States with more than 1000 patent applications. He was not very open to the theoretical nature of alternating currents since he was more an inventor than a mathematician or physicist. The same was true of Tesla's theory in other single-phase and polyphase structures. Westinghouse, like Edison, was an inventor, but he also was an engineer. He provided financial support to establish an AC network. Edison has been very much at the hands of AC's power and its dangerous existence in the literature. This is noted. He performed various public relations campaigns using AC driven electrocutes. Finally, the transformer invention of Westinghouse made alternating current the best option to produce and transmit electricity.

Whenever your vehicle is started, a cordless drill is used, or some form of DC system is used. To distinguish positive from adverse charges, the battery in your car utilizes chemical energy, which produces a possible

difference between its terminals to generate 12 VDC to transform the engine. The drill is fitted with a similar device for the battery in your cableless drill. Electronic equipment, except portable equipment, transforms incoming electronic equipment into DC using a rectification method. The lights in your office, the recipients you plug into your home, and the big motors of the factory are examples of equipment using AC. AC power is generated and transmitted at a frequency of 60 Hertz in the United States. The AC waveform varies from time to time to model its behavior by using a sinusoidal function.

Five electrical properties need to be added to assist with the research of circuit theory. These include resistance, power, inductance, reaction, and impedance: the regular resistor, condenser, and inductor symbols .

Resistance (R) can be defined as an adverse charging or current flow property for the material. The resistance unit is the ohm; Resistors are a part of the current flow.

Resistor displays a circuit with series resistors and parallel circuits with resistors. It should be remembered that the current is the same across each element in a sequence of circuits, while the voltage is the same through each element in a parallel circuit.

Capacity (C) can be described as the property of a material to prevent any voltage changes in the entire material. The capacitance unit is the size. Capacity occurs when the insulator separates two conducting materials. Two leading plates are separated by an insulator called a dielectric in a parallel plate condenser. The condenser can block DC signals and transmit AC signals. The condenser acts as a DC open circuit and a frequency selector system in AC under constant condition.

Inductance (I) can be defined as a material property that prevents any current change from the material. Henry is the unit of induction. Both drivers have an inductance, particularly those not coiled. Under steady conditions, the inductor can be defined as the opposition to the current flow of those components present under AC conditions like a short-circuit to DC and a frequency selective system to AC-Reactance or specifically capacitive reactance (X_c) and inductive reactance (X_l). The reactivity element is the ohm. These devices change their reaction based on the frequency applied .

Impedance (Z) can be defined by a combination of resistance and reaction in an AC circuit as complete opposition to current flow. The impedance element is the ohms. Impedance allows the study of a complex AC network in the frequency domain under steady-state conditions using the same techniques as in a simple DC circuit.

The Kirchhoff Voltage Law (KVL) and the Kirchhoff Current Law (KCL) are two other fundamental network theorems. KVL means that the algebraic number of voltages decreases and rises in voltage is equal to zero in the closed-loop of a circuit, also called a mesh. KCL states that several current algebraic at a node that identifies a node as a junction of three or more current paths is empty.

Five other network theorems that are extremely useful for circuit simplification and analysis are:

The Superposition Theorem

Thevenin's Theorem

Norton's Theorem

The Maximum Power Transfer Theorem

Delta/Wye – Wye/Delta Conversion Theorem

The Superposition Theorem enables you to start solving complex systems using multiple voltage sources and is very useful for the simplification and analysis of circuits.

Thevenin's theorem can transform a complex network into a straightforward circuit, analogous to the Thevenin voltage source and an analogous Thevenin series resistor.

The Norton theorem allows you to transform a complex network to a single circuit with a current equivalent source from Norton and a parallel resistor equivalent from Norton. In electronics applications, these three network theorems are constructive.

The Maximum Power Transfer Theorem defines maximum power from the source to charge when the internal load resistance equals the total resistance of the source. This theorem is very useful for applications of power and communication. You find it easy to switch back and forth between a Delta-

connected network and a Wye-connected network with Delta/ Wye / Wye Conversion Theorem. In power and electronics applications, this theorem is extremely useful.

In AC networks with condensers and inducers, the principles learned from DC circuit analysis using resistive networks can very readily be implemented. Upon converting the capacitance and the inductance values at the defined frequency to their corresponding capacitance and inductive response values, new values of complex impedance can be added to the solution of circuit parameters used in resistive networks with the same methods.

SELECTING SOLAR POWER SYSTEM COMPONENTS

Solar Panels

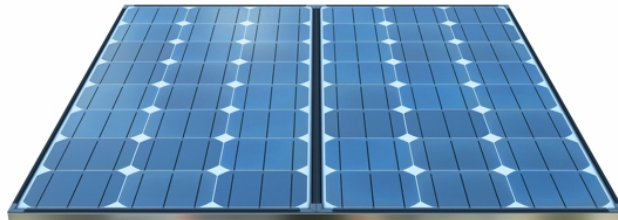

In short, a solar panel works effectively by allowing photons, or particles of light, to knock electrons free from atoms, generating a flow of electricity. Several smaller modules, called photovoltaic cells, contain solar panels. Several attached cells make up a solar panel. (Photovoltaic means only sunlight is transformed into electricity.)

Every photovoltaic cell is essentially a sandwich consisting of the same thing as the microelectronics with two parts with semiconducting material, normally silicon.

Photovoltaic cells have to generate an electric field to function. Much like a magnetic field that emerges from opposite poles, when opposing charges are separated, an electric field emerges. To accomplish this, the manufacturer 'dope' silicon with other materials, supplying a positive or negative electrical charge to each slice of the sandwich.

In particular, phosphorus is inserted into the top layer of silicon and contributes additional electrons to that layer, with a negative load. In the meantime, the bottom layer has a dose or a positive charge of boron, which contributes to lower electrons. All this adds to an electric champ at the crossroads of the silicone layers. Then the electrical field will fire the

electron of the silicone intersection when the sunlight photon shakes an electron free.

These electrons are converted into usable power by a few other cell components. The electron is captured and passed to the wires by conductive metal panels on the cell sides. The electrons will flow like any other electricity source at that level.

Recently, scientists have developed ultra-flexible, just 1/100th of a human hair's width, and is just 1.3 micrometers thick, 20-fold lighter than a sheet of office paper. The cells are actually so small that they can sit above a soap bubble, and yet they generate energy with as many efficiencies as the glass solar cells, scientists have recorded in a study that was published in the *Organic Electronics* journal in 2016. Their incorporation into engineering, aerospace technology, or even wearable electronics may be simpler, more flexible solar cells.

While solar thermal and concentrated solar power (CSP) technology is other than photovoltaic solar panels and utilizes sunlight power to produce electricity or to heat water or air. There is no such thing as solar thermal energy technology.

The solar panel includes three kinds of technology: monocrystalline, polycrystalline and amorphous thin film.

Monocrystalline and polycrystalline, as the names suggest, are both kinds of solar cells made of silicone. Crystalline solar panels are used for almost all of the quotes you get when purchasing solar panels for your house.

For many years, monocrystalline solar panels were the commonest form of solar panels in residential solar facilities in America. Over the past four years, however, polycrystalline solar panels in residential solar systems have been the most widely used solar panels in America.

Such kinds of CSPs in the industry are known simply as "mono" or "poly" tables.

You shouldn't lose too much sleep when choosing between monocrystalline and polycrystalline solar panels. It is more important to pick a good solar panel brand. A strong solar panel brand comes from a company that heavily invests in the quality and prestige of its manufacturing process.

Inefficiency is identical to both monocrystalline and polycrystalline solar cells. The fact that there is no flaw in the manufacturing process and that a manufacturer is replacing the panels if their performance falls below their guaranteed level is what ultimately determines the device efficiency over the lifetime of the solar panel .

Thin-film is a technique entirely different. It is much cheaper and requires a lot of roof space. Its key benefit is that it operates best when the machine is partly shaded or in intense heat in low-light conditions.

Overview and Appearance of Monocrystalline

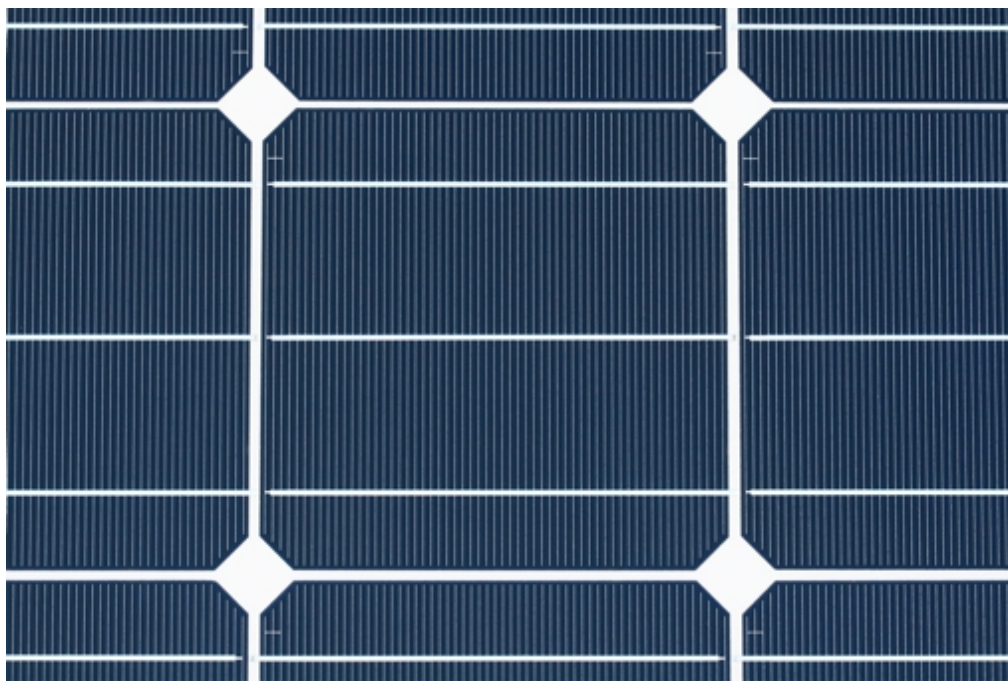

Monocrystalline: This is the oldest of the three technologies, the most advanced. As the name means, monocrystalline panels come from a single continuous layer of crystal. From solar cells, all of which display as one flat color, a monocrystalline panel can be described.

Building

The silicon crystal 'Seed' is put in a vat of molten silicon via the Czochralski process. The seed would then slowly be formed into a solid crystal structure around the seed known as an ingot, which is molten silicon. The developed length from solid crystal silicone is finely cut ingot called silicon wafer. It then becomes a cell .

The method of Czochralski leads to large ingots; To produce silicon wafers, four sides are separated from the ingots. The initial silicone ends up as waste in a large amount.

Overview and Appearance of Polycrystalline or Multicrystalline



Polycrystalline is a modern technology of different manufacturing processes.

Polycrystalline construction also starts with a "seed" of silicon crystal in a molten silicon vat. However, the silicon vat is allowed to cool instead of drawing silicon crystal seed as with monocrystalline.

This is the characteristics of the solar cell's edges and grains.

In previous years, polycrystalline cells were thought to be significantly less effective than monocrystalline cells. However, they have become the dominant technology on the residential panel market because of the cheaper way they can be used — combined with only slightly lower efficiencies —.

A new milestone for p-type multi-crystalline solar cells has been the continuous quality improvement of polycrystalline wafers, which over the last five years have led to the upgrading of standard 60-cell polycrystalline panels from 240W to 300W.

Polycrystalline cells are now very effective in their comparison to monocrystalline cells.

Thin-film panels reflect a technology completely different from mono and polycrystalline panels. Compared to monoblock and polycrystalline cells, these are the latest technologies and will not be regarded as mature as substantial technical advances would be anticipated in the next ten years.

The solid black appearance of a thin film panel can be identified.

Thin-film panels are rendered into a solid surface like glass coated with a photovoltaic material. The photovoltaic material used differs, and many material combinations have been successfully and commercially used. E.g., Amorphous Silicon Cadmium Telluride (CdTe) Copper indium gallium selenide (CGIs) Teint sensitized (DSC) each of the above panels is known as the 'forms,' both of which fall into the thin film group.

Thin-film cells are considered as the 'worst' of solar panel technologies because their performance is lowest. This is only because they have lower power output, meaning that most room is required for the same capacity. Because of the low cost of material for the thin film, they are the cheapest panels to manufacture, and they rapidly develop into the economically more competitive types of panels.

Only a few years ago, the output of the thin film was in one digit. Researchers recently achieved an output of 23.4-percent with the prototyping of thin film. In the meantime, commercially available thin-film panels are usually within the range of 10 – 15-percent.

In 2013, nearly 5-percent of American photovoltaic module shipments in the residential industry was focused on thin films, which are expected to rise at an annual rate of 23-percent between 2020 and 2025.

Advantages of Monocrystalline

The highest performance values are in monocrystalline panels, as they are made of the highest quality silicone. SolarCity revealed it had built the most powerful solar panels in the world on October 2, 2015. About 22% of sunlight is converted into electricity by the new panels.

Only days later, Panasonic declared his performance. A new world record conversion efficiency of 22.5-percent for a commercial prototype with mass

production-based solar panels has been set by Panasonic solar panel. The findings of tests were verified by the well-known Japanese National Advanced Science and Technology Institute. The prototype with 72-cell, 270-watt features newly developed enhanced technology, which will eventually be reduced to volume output.

Panasonic has also announced its latest addition to the company's high-efficiency HTMP product line and the most efficient PV module to date, the HIT ® N330. This will be available from March 2016 both in the UK and other European markets. HIT ® N330 has a 19.7-percent module-level capacity, and a nominal performance of 330 watts, installed in Panasonic's state of the art vertically integrated solar manufacturing facility in Malaysia.

Solar panels are space-efficient with monocrystalline silicon. Because these solar panels provide the highest electricity production, they are also less room than any other type. Monocrystalline solar panels, however, generate marginally more energy per square foot of the space in a range and so on.

The long life cycle of monocrystalline solar panels. In their monocrystalline solar panels, most solar panel manufacturers placed a 25-year warranty. As crystalline silicon is a very inert and durable material, all forms of crystalline solar panels are very likely to last for more than the 25-year warranty life of these solar panels.

In warm weather, monocrystalline solar panels are more effective. Electricity production decreases as the temperature increases for all solar cells. In monocrystalline panels, this loss of power is less extreme than polycrystalline solar panels. The difference is, however, very small in reality. The level at which each output of the solar panel falls as a rise in temperature is called the temperature coefficient and is recorded for each panel according to the specifications.

This part covers only different solar panel types. You should go to the Solar Power System if you want to know what other photovoltaic systems consist of.

The drawbacks of the monocrystalline solar panels are the most expensive. The rush in installing polycrystalline, cell, and module output efficiencies in recent years has resulted in the growing use of polycrystalline solar panels and the advantages of costs over mono-panels. Maintaining mono-panels, several manufacturers target the luxury market end.

Advantages

The method for processing polycrystalline silicon is easier and cheaper. Compared to monocrystalline, the volume of waste silicon is smaller.

Polycrystalline solar panels are typically marginally more robust than single-crystalline solar panels. Polycrystalline solar panels tend to have a higher coefficient of temperature than single-cell solar modules. That means that this type of cell's heat would decrease. Such variations are, however, very limited in reality.

Polycrystalline solar panel's inconvenient performance is usually 14-16% for multi-crystalline solar panels. Polycrystalline solar panels are not as effective as monocrystalline solar panels due to their lowness of silicone purity.

Lower efficiency in space: To generate the same electric power, you usually have to cover a larger surface than yours with a monochromatic silicon solar panel. This does not, however, mean that each monocrystalline solar panel is better than polycrystalline silicon panels.

Sunlight panels monocrystalline and thin-film seem to be better because they look more smooth compared to the polycrystalline silicon's speckled brown.

Advantage of Thin-film Solar Panels

- Mass production is fast. This makes the manufacture of crystalline solar cells theoretically less costly.
- Looks more attractive because of their homogeneous appearance.
- It can be versatile, and several new applications are opened.
- High temperatures and shading affect the efficiency of the solar panel less.
- If space is not much of a concern, thin-film solar panels can be important .

In general, thin-film solar panels are not as useful for most residential conditions. Thin-film solar panels; they are inexpensive, but they need plenty of space. Monocrystalline solar panels of SunPower generate up to

four times the amount of energy for the same amount of space as thin-film solar panels.

Furthermore, the cost of PV equipment (e.g., cables and support structure) would increase by lower space capacity.

Thin-film solar panels appear to degrade faster than solar panels that are monocrystalline or multi-crystalline; thus, they are normally given a smaller guarantee.

SOLAR CHARGE CONTROLLER

The power from the solar array reaches the battery bank by a solar charge device. They ensure that the deep cycle batteries are not drained during the day, and that energy does not run overnight back to the solar panels to drain the batteries. Many charging controls with other capabilities, such as lighting and load control, are available, but the main job is to manage electricity.

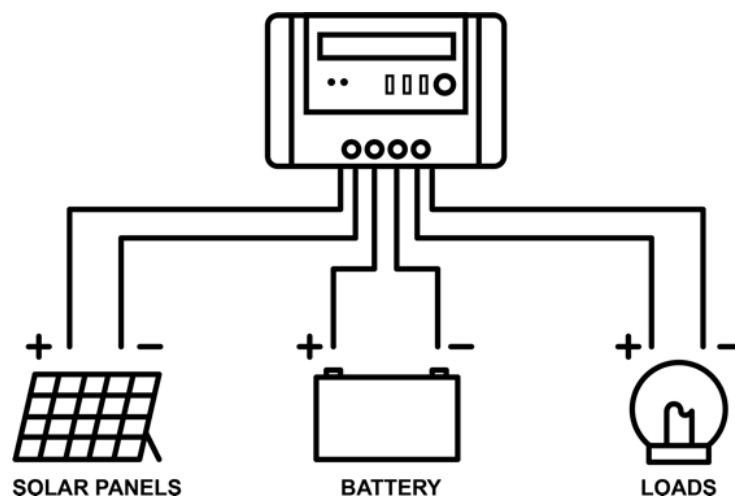

A power controller is known as a solar charge controller from the individual solar panels to batteries. For systems that use batteries, the device is essential. If it is overloaded, battery life can be reduced. For the same reason, too, the battery can be damaged. A solar load controller avoids such. The solar charge controller controls the battery voltage, and the circuits are opened so that charge can be stopped at a certain point when the voltage is present .

The older versions of the device use a mechanical relay. The circuit will be manipulated in this process to stop or start the power from the battery entry. Modern version modulation techniques use PWM or Pulse Width so that the power that reaches the batteries when fully charged is gradually decreased. This is a better option because the battery is less stressed, and thus the lifespan of the battery is improved. This system also tracks whether or not the battery is fully charged.

Other solutions are also available such as MPPT or full PowerPoint; an excess voltage can be converted into amperage by the solar charging system. This also means that the charge voltage is sufficient, and the battery needs less time to recharge. The power between the wires is normally immense, but with the MPPT, it can reduce waste. MPPT is cheaper than its competitors, but it's a decent option when you look at the advantages.

Current Reserve Flow Solar Charge Controller

The Solar Charge Controller can also be used to monitor reserve current flow. In the night, solar panels are typically not needed to produce power, and the batteries can then drain power in use. Eventually, this results in energy wastage and eventually, money loss, which can be avoided by a solar charge device. Firstly, the solar charge controller tests if the solar panels are used to produce electricity and then disrupts the batteries automatically through the opening of the circuit, thus stopping the reserve flow .

Protection

You can also see how solar energy is not efficient because it comes from the sun, and there is no system for controlling the amount of power you get from it in a day. However, solar systems are designed to optimize advantages in the most optimal circumstances. So, when you want it, a higher voltage is possible.

A solar load controller simultaneously ensures that the excess voltage doesn't harm your system. At some times, it measures the voltage of a solar panel and then reduces it to a degree of protection. This helps the solar charging controller to focus more on the solar systems and ensures that no harm is done.

Well, there are solar charging controller expenses, and this is the only drawback this system has. This is now almost a requirement for you, whether you use solar power for your company or household.

Two separate systems, PWM and MPPT, provide a solar charge monitor. This is very different from how they work in one system. An MPPT load controller is more costly than a PWM load controller, so the expenditure of extra money also matters.

A PWM solar charge controller stands for "Modulation of the pulsed range."

PWM SOLAR CHARGE CONTROLLER

They work by attaching the battery bank directly from the solar array. During mass charging, the array output voltage is 'pulled' to the battery voltage if the array is continuously attached to the battery bank. The voltage of the battery increases as the battery charges so that the solar panel voltage is increased by increasing the amount of solar power used. You must ensure that you suit the solar array nominal voltage with the battery bank's voltage. What is meant by referring to a 12V solar panel is a 12V battery-driven panel. Once connected to a load, the real voltage of a 12V solar panel is nearly 18 volts (maximum voltage). That's because the battery requires a higher voltage source. The battery would not charge as the battery, and the solar panel both started at the same voltage.

You can charge the 12V battery by a 12V solar panel. For a 24V battery bank, a 24V solar panel or a solar array is required, and the 48-V array for a 48V bank. You're tossing more than half of the energy out when you try to charge a 12V battery with a 24V solar panel. You would throw off 100% of the panel's capacity when you try to charge a 24V battery bank with a 12-V solar panel and can potentially even drain the battery.

MPPT SOLAR CHARGE CONTROLLER "Full PowerPoint Monitoring" MPPT Solar Load Controller

The vmp voltage and the PV voltage is downgraded into the battery voltage. Due to that, as the voltage is lowered to match the battery bank, the current is increased when the charger control is electrical, and you use all of the power from the panel that you can get. You can use a high-voltage solar panel rather than a battery, like the more readily available 60-cell nominal 20V grid-tie solar panels. You can charge a 12V battery bank with a 20V solar panel, or two of them can charge you up to a 24V battery bank, or up to three of a 48V battery bank in sequence. This opens up a wide range of solar panels that are now available for your off-grid solar system.

The most important job of all solar panels is to charge the batteries properly and give them a full lifespan. There are two kinds of load controllers: Pulse width modulation (PWM). The difference between these two types is that

the PWM is not as effective as the MPPT. The MPPT is the best in today's world and can provide you with up to 30% more power than the PWM controllers. The MPPT controls allow the panel strings for higher voltages to be connected in series, which allows a lower amperage and smaller wire size, particularly for long wire runs on the PV array.

If you want a charging controller, you need to take a few precautions to ensure you have the appropriate controller for the job. The perfect thing you can do is to use the sizing software provided on their websites by the manufacturer. The other choice is to call the supplier — the salesmen usually help you select the best controller.

For fast calculations, the information required is the following: solar array wattage. The battery-base voltage (12, 24, or 48) for the controller's amperages to be calculated manually. Typical bank voltage, as these voltages are supplied with inverters .

Then Ohm's Law comes in: Amps x Volts = Watt Example: 3,000-watt battery bank array = 62.5 amps so that you need a 62.5 amp controller. There are either 60, 80 or 96 amps in most controllers so that you can choose the controller with the following higher score. It is the 80 amp controller in this case.

Now that you have been made familiar with the controller amperage, and you want to find out how the maximum solar panel wattage you can use is the Ohm Act: for example, 80 amp controller x 48-volt panels = 3.840 watts solar panels. Note that most controllers are allowed to go into controllers with a bit more wattage. Here are the methods for calculating or calling the maker.

First, you have to ensure that the input voltage the controller will take does not surpass the limit. The supplier must again decide what the input voltage will be in the system. It must be taken into account temperature and open-circuit voltages. As the PV open circuit tensile voltage (Voc) rises as temperature decreases, this can be done in winter in the cold by the controller. The sizing instruments from the manufacturer provide the controls with the best configuration.

THE SOLAR CHARGES CONTROLLER ARE

Battery bank recharge over several phases – transfers low-level power to a low-level for healthier batteries.

Reverse current defense- when there is no power coming from, and the solar panels stop the panels from draining batteries at night.

Disconnect low-voltage – disconnects the battery load when it is weak and turns the battery back on when it is powered.

Regulation of lighting-switches on and off the light based on dusk and dawn. Most control units can be programmed to require a few hours of settings or overnight settings.

Display- can view battery bank voltage, load status, solar panel amps.

BATTERY

There is a growing interest in energy storage. There is no longer all about living off the grid. Storage aims to address renewable energy volatility issues. Adding a solar battery to a residential network project will enable the array, instead of disconnecting or refraining from generating electricity, to maintain power at critical loads when the grid falls. Stockpiling will also reduce peak demand charges for industrial customers and significantly lower their energy costs. Storage is used to provide the grid with secondary resources and at the utility point. The need for storage would increase as states implement self-consumption and other battery-friendly laws .

The demands of unreliable grid electricity, fast cycling (charge and discharge), and intermittent full-challenge recharge in solar applications must be addressed. Such specific requirements are met by a variety of battery types: the cost, cycle life and installation, and maintenance of battery selection considerations.

Here you can look at these aspects of each technology and some best practices in the selection of solar batteries.

The Lead Acid Deep cycle of plumbing batteries have been used in renewable energies for decades and are consistently used worldwide in off-grid applications.

Cycling: Batteries with VRLA include absorbed glass mat (AGM) and gel types.

Battery size: Most AGM batteries on the market are mainly designed for dual or standby applications such as emergency backups but not deep cycling. Nevertheless, modern deep-cycle AGM designs have improved efficiency and total energy output, allowing renewable energy applications to choose at a lower price than gel batteries.

Also, nanocarbon-induced VRLA batteries are more sulfur tolerant, which may result in batteries dying over time. The carbon slows down sulfation and allows the battery to charge more quickly and cycle faster than conventional plumbic acid. For applications where the battery is in partial charging, such as the power arbitrage or off-grid, this makes it a good option .

Replacement/maintenance: Many factors, including original design and continuous maintenance, affect the life of the battery, so it is difficult to devote time to substitute battery items. Batteries with flooded plum acid have to be refilled periodically because the electrolyte in which the battery plates are fully submerged evaporates during charging. The enclosure requires ventilation to avoid the accumulation of hydrogen gas to dangerous levels.

AGM and gel technologies, however, are recombinant, which means that hydrogen and oxygen are internally converted into water, and no maintenance is needed. As the battery is free of acid, it can be mounted in any other than upside-down location. Since solar installations can be difficult to reach or remotely, the ability to mount the batteries and run without maintenance for long periods is an advantage.

Disposal: Proper disposal is necessary because of their toxicity for lead-acid batteries. Fortunately, the car industry initiated the early recycling of lead. Old batteries may also be neutralized, replanted, and in new battery boxes used in plastic containers. In some cases, the electrolyte is washed, recycled, and sold as an electrolyte battery. The contents of sulfate are otherwise extracted and used in fertilizer like ammonium sulfate. As a source of fuel for the recycling process, the separators are often employed. The battery dealer, auto service station, battery supplier, or other approved recycling collection hubs shall be permitted to return old batteries.

The Solar Energy Monitor states that, regardless of application, lithium-ion batteries are the most popular storage technology. There are three kinds of pouches: cylindrical pouches like on smartphones and tablets, power tools, and colorful (in different shapes), like electric vehicles. There are three. Prismatic forms usually have corrugated surfaces that create air gaps between adjacent cells, which can help to cool. Prismatic can be used in solar storage applications, especially lithium-iron-phosphate (LFP) batteries.

Cost: At the end of 2014, lithium-ion batteries were valued by Deutsche Bank analysts at about \$500/kWh, although one supplier has reported that they are nearer to \$750 to \$950/kWh. In general, they are cheaper than batteries with plum acid. Much of this expense comes from the need for unnecessary recharging and discharging battery control device to track the voltage and temperature of each cell. For other technologies such as lead-acid, a BMS is not necessary because the battery charging regime can be done by an inverter or charger controller. Some manufacturers remember, however, that, if the cells are designed correctly, the cost of peripheral devices such as cargo controls may be minimized by compensating for their higher initial price and reducing owned costs.

Cycling: Lithium-ion batteries typically have more cycles than lead-acid. This makes it a good choice when batteries are cycled to provide supplementary services to the grid, including energy smoothing or frequency and voltage support. Lithium-ion's key benefit for solar is its high load and release capacity that leads to further energy harvesting. The lithium-ion battery also loses less power in idling installations where only occasional energy is used in solar installations.

Replacement/maintenance: The batteries of lithium-ion are lighter and stored in themselves than the batteries of lead-acids, making installation and exchange simpler. They can be put on a wall and can be placed inside or outside. They are sound, so no refills or maintenance are required.

Elimination: Batteries may use organic or inorganic cells. Lithium-ion batteries. Batteries that are organically based are toxins safe. Inorganic cells are also harder to kill. Inorganic lithium-ion is harmful and should, therefore, be properly disposed of. Herstellere support recycling, but sometimes prices are present—the economic value of spent lithium-ion

batteries. The production of lithium-ion requires lengthy raw material processing and purification. In recycling, a similar method has to be followed again, so that it is often cheaper than to recycle the new material.

Battery flow is that in long-term storage. Two electrolyte liquids are used in modern flow batteries: one with a negative cathode and one with a positive anode. The anode and cathode are divided by a membrane in two tanks as the battery will shortly and require replacement if they come into contact. This is typically the case for lithium-ion batteries, and over time the membrane degrades. Nevertheless, the exchange of negative and positive fluids in flow batteries produces without degradation electric current, giving a longer cycle life and quick response times .

Cost: Flow batteries often stand above lithium-ion in long-term storage applications when looking at the assessed storage costs. This is because they have been able to reuse or sell electrolyte products with little maintenance over the past decades.

Replacement/maintenance: The membrane of the flow battery is a little longer than other systems so that the flow batteries last. Even low-maintenance required is flow batteries. The only way to maximize storage hours for other technologies is to add more batteries—flow battery benefits from simply adding more electrolyte to increase the storage space.

Cycling: developers of flow batteries claim the technology does not have cycling restrictions, and without affecting their lifetime, batteries can be fully charged and discharged.

Destruction: while chemistry depends, flow batteries are less reactive and readily available without a fire risk. The electrolyte can be recycled several times, helping to reduce the reduced storage cost for flow batteries.

In the early 1900s, nickel-cadmium nickel or NiCd batteries were available. While the energy density (power) of other technologies may not be available, they ensure long life and reliability without complex systems of management.

Cost: Cadmium nickel, in contrast to other technologies, is relatively inexpensive .

Replacing / maintaining: The batteries of NiCd are released to permit the dissipation of gases. Traditionally some watering is needed, but modern

designs allow the gases to recombine to form water, rendering the battery almost maintenance-free. This makes these batteries ideal for off-grid applications in harsh environments, combined with the possibility to tolerate extreme temperatures. They were used in megawatt projects for storage.

Batteries with the NiCd are robust, cycle-long batteries. Some companies are offering up to 20 years of service life.

Cadmium is a dangerous material. Disposal: Europe is currently restricting the use of NiCd batteries. Before the battery is disposed of, toxic materials must be removed. Batteries from NiCd, however, may be recycled. New batteries can extract and reuse cadmium. It is possible to extract nickel and use it to produce steel.

Using a Sizable Calculator

The size of the battery is important, but users and installers sometimes lack the right battery. PV devices typically underestimate batteries due to the cost or underestimation of device loads. It is necessary to know the power needs of the customer and prepare properly. Much online battery and other software calculators simplify the determination of battery load requirement efficiency.

You have certain requirements to use in the assessment of your solar battery choices, such as the length of the solar battery or the power supply. Below, read all the requirements for comparing the energy storage choices for your home and the various types of solar batteries.

Comparison of your solar storage choices You can find a lot of complex product requirements in your solar-plus-storage choices. The battery capacity & power ratings, DoD range, round-trip performance, warranty, and supplier are the most critical to use during your assessment.

The cumulative energy that can be stored on a solar battery consisting of kilowatt-hours (kWh) is Power & Energy Efficiency. Some Home solar batteries can be "stackable," so several solar-plus-storage batteries can be used to get additional power.

While your computer is capable of telling you how much energy a computer can produce at a given moment, it doesn't tell you. You will have to take the

battery power level into account to get a summary. The amount of electricity a battery can generate at a time is the energy rating in the sense of solar batteries. The calculation is per kilowatt (kW).

A large battery with a low power rating would provide a limited amount of electricity for a long time (sufficient to operate a few critical devices). Your entire home could run on a low-capacity battery with a high power-rating for a few hours only.

Download Depth (DoD)

Due to their chemical composition, most solar batteries must maintain some charge at all times. Using 100% of the battery charge will substantially shorten its service life .

The battery's DoD refers to the quantity of the power of a battery. The maximum doD is defined for optimum performance by most manufacturers. For instance, if you have a DoD of 90% of a 10 kWh battery, before recharging it, you should use more than 9 kWh. In general, a higher DoD ensures that you can use more of the power of your battery.

The Output of Round Trip

A battery's round trip output reflects the amount of energy it can use to store the device. For example, the power of the battery is 80-percent rounds ($4 \text{ kWh} / 5 \text{ kWh} = 80\%$) when you pump five kWh of electricity into your battery, and only 4 kWh of usable electricity can be recovered. A higher round trip performance would usually mean that your battery gets more economic value.

Battery Life & Warranty

Your battery must "circuit" (charge and drain) regularly for most use of home energy storage. The capacity of the battery to carry a charge will diminish more slowly. But solar batteries are like your cell phone's battery – every night, you charge your phone for use, and as your phone gets older, you'll find that the battery doesn't retain as much power as when it was new. A battery, for example, can be assured at 70% of its original capacity for 5,000 cycles or ten years. It means the battery has lost just 30-percent of its initial energy storage power at the end of the warranty .

Your solar battery has a warranty that provides a certain amount of useful cycles and years. Owing to the inherently weakening bacterial efficiency over time, most manufacturers often ensure that throughout the warranty, the battery retains its power. So it depends on the type of battery you are buying and the amount of power it will lose over time. This is the only answer to the issue: How long will my solar battery last.

Manufacturer

Several different types of organizations, ranging from automotive makers to technology start-ups, are developing and selling solar battery products. While a major automotive maker that enters the energy storage business undoubtedly has a long history of automobile development, they do not have the most advanced technical features. A technology company could then have a brand new high-performance device, but it could not have a track record to show the long-term reliability of the system.

Depending on your preferences, whether you want to use a battery developed by a state-of-the-art start-up or a manufacturer of several years. An evaluation of warranties for each product will provide more guidance when you decide.

THE ENERGY STORAGE TECHNOLOGY

Home energy storage and electric vehicles are very much alike: both use advanced batteries to make more efficient and sustainably manufactured goods, which can reduce greenhouse gas emissions.

More companies invest substantial research and development funds on battery production, as electric vehicles become more popular, and they grow into the energy storage market. Tesla has been the first big example (with its Powerwall battery), but in 2017 even the stand-alone batteries are launched by Mercedes-Benz and BMW.

How Long Will Batteries with Solar Energy Last?

This question can be answered in two ways, and the first means deciding how long a solar battery will power your house. Sometimes, when your solar panels do not generate electricity, a fully charged battery will power your home overnight. To make a more precise estimate, you would need to consider a few factors, including the amount of electricity used in your household on a given day, what your solar battery's efficiency and electricity rating are and how you are connected to the power grid.

For a simple example, we are determining the battery size necessary for providing a sufficient solution for solar plus storage with national mean U.S. data. Administration of Energy Knowledge. The U.S. household would use up to 30-kilowatt-hours (kWh) of energy per day, and a standard sunbath will provide around ten kWh of power. So, a quick reply is that you can run your homes all day long with nothing but battery support when you purchased three solar batteries.

The response is much more complicated. You will also produce power during the day with your solar panel system that will deliver good power during peak sunlight hours for around 6-7 hours a day. On the other hand, most batteries do not run at full power and typically at a DoD of 90% (as mentioned above). It will have a useful power of 9 kWh for your 10 kWh battery.

Ultimately, if your panels are not made, you can provide enough energy at night when one or two batteries are combined with a solar photovoltaic

array. But you can need three batteries or more to power the whole of your home for 24 hours without a clean energy solution. If you install a home energy storage system, you can also set up several days of backup power to cover the days of bad weather when you need it to detach from the electricity grid.

The average period for a useful life of a solar battery is from 5 years to 15 years. Solar battery lifetime If you now mount a solar battery, you will possibly have to substitute it for the life of your P.V. device for 25 to 30 years at least once. However, just as the life cycle of solar panels in the last decade has increased significantly, solar batteries are usually expected to follow suit as the energy storage solutions market grows.

Proper maintenance may also have a significant effect on the lifetime of your solar battery. The temperature of solar batteries is greatly impacted, and your battery can boost its useful life by protecting against freezing or swelling. The lower the voltage of a P.V. battery, the lower the 30°F voltage is needed, the higher the voltage the battery can increase, the less the load, and the higher the 90°F threshold. Most leading battery manufacturers, such as Tesla, offer temperature control as a feature to solve this issue. But you do have to find other options, such as earth sheltered boxes if the battery you purchase does not. The maintenance efforts of consistency will undoubtedly affect the duration of your solar battery.

What is the safest solar battery?

Home energy storage batteries typically consist of one of three formulations of chemicals: plum acid, lithium-ion, and saltwater. In most cases, the best choice and option for a solar panel system is the lithium-ion battery, although other battery types are more affordable.

Lead-acid Batteries

Lead-acid is proven batteries that have been used for decades in off-grid power systems. While their lives are fairly short and their DoDs are smaller than other types of batteries, they are still one of the cheapest choices currently available on the home power storage market. Lead-acid can be a good choice for homeowners who want to leave the grid and need a lot of energy storage.

Lithium-ion

Many modern energy storage technologies such as lithium-ion chemical composition use some form of lithium-ion. Batteries of lithium-ion are lighter and more compact than batteries of plum acid. They do have a higher DoD and lifetime than batteries with acid. Lithium-ion batteries are nevertheless more expensive than their counterparts in lead-acid.

Saltwater

The saltwater battery is a newcomer to the domestic energy storage industry. In comparison to other domestic energy storage, the saltwater batteries do not contain heavy metals but rely on saltwater electrolytes. While heavy metal batteries, including lead-acid, lithium-ion batteries, have to be removed with special procedures, it is possible to recycle a battery with saltwater easily. Nevertheless, the only company that produces solar batteries for home use (Aquion), which submitted bankruptcies in 2017, has been relatively unproven in the form of new technology.

SELECTING AN INVERTER

How to pick the inverter for your needs

All inverters transform the DC electricity to alternating current (AC) energy. The similarities between inverters stop here. Today customers have access to an overwhelming amount of products and choices. The best decision depends on whether the inverter is to be used. Options range from small mobile power plants to medium-sized power stationary inverters to power homes in rural, rural, and urban areas to large-scale inverters and inverter groups linked to small and larger companies.

Mobile Inverter



The mobile energy specifications include the availability of smaller inverters of 100 to 2000 Watts or more for marine, RV, and other smaller, off-grid applications, such as a tool shed, or barn. These mobile inverters are designed for areas without electricity used to convert the electricity of a DC battery from an electric motor or an independent power supplied, such as a solar panel, wind turbine, or engine generator. This power supply unit is a power supplier. Sea converters are designed to withstand harsh conditions of weather and corrosion from exposure to saltwater, so choose the form of seaworthy when you intend to use your inverter on a boat.

You can choose between pure sine wave inverters or what is known as a square wave or modified square wave inverter depending upon the types of appliances you are operating and how reactive they are. Modified square-wave inverters are less costly than pure sine-wave inverters because their conversion is less complex and has more choppy transitions in the

alternating current output. Modified square-wave inverters operate these motors faster, using a 30% higher power injection while using machines that have motors (such as refrigerators, fans, drills). Rather than round, it's a bit like driving a car on square wheels. The car is going to push forward, but the journey will be much less effective and bumpy.

A bad waveform can cause overheating, damage to equipment, or even cause a complete failure for certain equipment and electronics, such as engines, TVs, and computer and battery chargers for cordless devices. Other potentially difficult problems are inverter noise on devices such as compact fluorescent lamps, radios, stereos, and TVs. For most people, the little price difference makes it worth buying a pure sinusoid inverter first so that later, when they decide to use their inverter for another product, they do not face limitations .

You need to have an adequate idea of the numbers of watts your devices need to work continuously, the number of various tools you want to use at one time, and what amount of power you have when you start up, or how much power draw, as with certain larger motors, with instance power saws. When using your mobile inverter, it is important to know how much power you want to use and what power it needs.

This information is generally contained with each device on what is known as a "name board." It can be contained in watts or volts and amps. The quantity of watts ($V \times A = W$) is indicated by the multiplication of the volts times the voltage. See the specifications, calculate with an ammeter, or "guesstimate" by multiplying the continuous watts three times to assess the power surging requirements (though the surge can often be more than seven times).

The biggest proportion of inverters sold today on the worldwide market is for home energy systems. Throughout the early years of industry, inverters were designed for remote, off-grid operations in which commercial electricity was not usable. Today, however, most inverters in developing countries are used on-grid applications where feed-ins or interstitials can be used to produce and deliver clean, renewable energies through the larger public utility networks—transferring some energy historically generated by coal and oil combustion or nuclear reactors.

Two entirely different types of needs are met by off-grid and on-grid inverters. On-grid inverters are split into two different types — both with and without battery power. The type of inverter you need depends on whether or not you have a service on your premises, and how effective that service corresponds to your requirements when it is available.

The first inverters were as simple as they were; they offered the ultimate convenience and modern comforts for living far from civilization in desert areas. While the market in the U.S. remains small, off-grid systems are more prevalent in countries that have a national infrastructure that is less advanced. No matter where you live when your property is off-grid, it can cost much more than setting up your electrical off-grid network, just for a short distance.

Off-grid inverters are much more advanced today with battery monitoring and charging capabilities, automatically turning backup power on to make it easier to manage, easier to run, and free of concern. Like mobile systems, though for off-grid homes, the less costly inverter is usable; the price difference hardly balances the downside and drawbacks, even for the most rudimentary systems in the cabin and remote applications.

The best inverter to use for your off-grid network is dependent on the measurement of your electrical loads and patterns accurately. This evaluation must be performed with total integrity and consideration so that the whole system is sizable and runs smoothly. The size converter you need is based on the specifications of your "peak load" – all the AC loads which can be triggered simultaneously .

You can find that your load calculation exercise needs to be addressed more than once in your planning phases.

So minimizing your loads would result in massive savings as far as your system is concerned and how long your backup generator will need to work. The industry's traditional axiom is that each dollar invested in productivity would save between \$3 and \$5 in device costs.

Another factor in the careful management of a home energy network is inverter efficiency. When operating at or near their peak output, the inverter is normally most powerful, such as a 1500watt inverter, which can handle a power of almost 1.500watt.

Much of the time, however, you have a wide variety of loads on your inverter, normally at its highest. Pick a high-performance inverter over a broader range of loads. Other considerations include the relationship of an inverter with the input voltage (usually 12.24 or 48 Volt) and the corresponding output voltage, i.e., 120 or 240 Volt. Collect and research the manufacturer's requirements and ask pros for guidance in connection with potential questions.

On-Grid Without Backup

The battery backup integrated utility network is the easiest and cheapest alternative to use in domestic energy systems. For this device, all needed are solar-electric modules and an inverter connected to the main panel of your house, together with a disconnect and a separate meter depending on the specifications of your local utilities.

Where "net metering" is in place, the inverter feeds any solar power that is not used by your host on the power grid, and your account earns the credit for surplus output. When you do not generate electricity, e.g., in the evening, the energy needs of your home are covered by the business. Net meters will reduce the electricity bill monthly and supply the country's power grid with renewable energy.

In most countries in the U.S.A., net metering regulations have been passed. Nevertheless, even though the States have passed legislation requiring an operation, certain small electrical cooperatives and public utilities may not be allowed to participate. Check the laws of your State and review the needs of your service before deciding on such a program. In addition to the currently available federal tax credits, several states provide benefits like tax credits and will provide rebates for eligible programs. You will find out what is eligible, what needs to be met, and how to demand reimbursement by using the web-site above or by contacting the energy department of your state and the local utility company. (Any utilities also have special incentive programs.)

Choosing the appropriate inverter size is simple for this kind of device since it depends on how much the inverter is made. Next, according to your nameplate, you should know the number of total watts in your solar array. The defined watts are based on standard test conditions (STC) calculation of the performance. The study requires 77 degrees Fahrenheit ambient

temperature and total sunshine. Naturally, your solar panels won't always have the ideal conditions, so you need your calculations to take that into account. Cold temperatures improve the efficiency of the panels above STC, while warmer temperatures reduce production figures. Most manufacturers provide the right inverter for your size device to include online calculators or specification sheets that take into account local variables.

For a grid-free application, inverter efficiency and dependability are the biggest elements to consider when choosing between inverter brands. The majority of inverters on the market today have an efficiency rate of over 90%. This form of the device has the greatest downside: if the power loss happens, the machine will go down because the inverter will feel the presence of the grid and precisely adjust its frequency to operate. Get a battery backup system when you're concerned about power outages.

For Battery Backup On-Grid systems, a power backup network can be installed. Once you select this option, your battery backup systems bear the cost of adding and often reducing capacity.

Firstly, note how much and for how long the power supply has been down over the last five years. If you live in a country constantly faced with tornadoes or hurricanes, with power failures regular and longer than a couple of hours or a day, consider seriously adding backup batteries to your device. If, for example, you have vital loads in your house, or you have older people or people that are vulnerable in their house and cannot bear a power outage under intense heat and cold conditions, this is certainly the device for you. Or maybe you have a home business that constantly relies on electrification to keep you competitive, or your area is experiencing several rolling outs that are wrecked down by the loss of your computer data.

The majority of battery backup systems are designed to allow only one or two circuits which can hold your vital loads during a blackout for several days or more. This type of device uses power when it is available and transfers the battery load only in the event of a failure. If the power supply connects to the power source, charges are transferred again, normally recharging batteries with the battery charger of the inverter from the grid.

The choice of the inverter for these systems will depend on the capacity of your power generation system, whether solar or wind power, the amount of system operation and maintenance you need and the ease of installation. Certain important considerations, as well as the cost, are the warranty, reliability of the service, and the quality of the manufacturer, along with inverter efficiency ratings.

Larger Systems

Many manufacturers have high volume inverters and inverters that are suitable for industrial applications, ganged up in many systems to operate very large systems. However, work has been carried out on mini-grid systems in which a small number of households would share power output and battery storage .

Virtually any inverter can be worked on all household devices and other major electrical devices and equipment. As a result of a power outage, one makes use of an inverter as an emergency backup power generator and still uses your monitor, television, lamps, power tools, kitchen appliances, and other electrical conveniences, if it is optimally powered. This will, of course, also rely on the type of inverter used specifically for driving a combination of high energy-intensive machines, fixtures, and equipment that has been planned or recommended.

In addition, gas generators, motor engines, solar panels and other modern power supplies can charge these batteries. They are also available.

HOW TO INSTALL A SOLAR POWER SYSTEM

The only option for inexpensive electric bills will forever be a solar panel system. Every year, solar cells become cheaper.

Right now, we live in a war. The energy conservation war has never been fought with the most sophisticated weapons, so all winners are those who pay less monthly. The first line of protection against electricity is to create a solar panel system on your own.

Some Steps to Help You:

1. Get Low-cost Solar Cells

You can pick from several solar cells. The Chinese have the best prices, with decent outcomes, but not a great deal and the Japanese have good performances, good quality, and guaranteed Japanese work. The Americans have promised over promises for the best performance, the highest price, and again. Carefully choose the budget.

2. Get Equipment

Find devices such as a soldering iron, solder, soldering paste or flux for removing grate from the wires, a pin, wooden glass plates, a tensile, and an amplifier multimeter. And a crayon and a ruler, of course.

3. Put square solar cells on the wooden board attentively and draw separating lines (carefully). After all, you're halfway.

4. Cheap Solar Panel System

Now start soldering the wires to the solar cells and then one another after you have designs on the physical arrangements of the solar cells on the wall.

Link the cells in series first. Compliance with this simple law, as if you soldered batteries: the positive lead is soldered to the negative lead of the following cell. Do this to achieve the voltage 12 or 24 volts for as many cells as possible. Do not exceed that because you reach the hazardous voltages field. You don't want to fool yourself and electrocute yourself to

death, and you want to generate significant power here. After all, power is still the same. Only start a 12V inverter with a minimum of 12 volts to produce 110/220V AC or charge your 12V packs of batteries. The voltage is increased by connecting the cell in sequence.

Then carefully add the cells to the surface. If you had a frame for them to be mounted separately, you would better be able to remove the faulty ones, if only.

Make sure that you drill holes individually for the wires before you have put all cells in the right spot! Allow link busses along the positive and negative lines and connect those busses parallel (greater lines) with the parallel relation (plus to plus, minus zero) to increase the amperage.

5. Finished!

You built the first solar panel system that works, and you can now use this system to see what it generates. The voltage must first be measured and the short circuit amperage then. Make sure your ammeter has the nominal capacity of the solar cells (108W means nine amps at 12V).

All on a DC stream can now be powered, your battery charged, etc. You could order many more solar cells until you have reached the power you want for your system if you succeeded in doing these five steps. The more power you want, the bigger the inverter you need.

The hardest aspect of building a solar system now is connected to a pack of batteries and then a converter, which calls for improved care and gravity like the work performed. You can use a UPS computer, but you need additional power to power your house. You can also use the UPS computer. However, the batteries must not be new and maybe the lead-acid kind, but you should buy specially made ones for power storage, and deep cycle use as car batteries can handle high cars for a short time, and you will lose them for good if they are unintentionally unloaded at a certain threshold.

Naturally, you can discover many secrets only through practice, but the general concept is that a device like this is simple. Or buy a used UPS (handle with care) from eBay, or better still. Then, when the Sun is across Europe (or vice versa), you might try to create a wind turbine to boost your power needs at night.

Step 1: Installing solar panels on the roof First of all, for the energy usage, you will need the right size solar system.

You will generally adapt your solar system to use around half the energy it generates on any given day.

In other words, your solar panels will generate about twice the power of your household. So your system will not only generate plenty of solar electricity to use but also export a large share of the energy to the grid, which will enable you to purchase credits.

You will have the right setup for your solar installer.

Be certain that you are eligible for any solar incentives until you accept your solar quote. You can be eligible for government rebate programs depending on your position and your revenue.

Step 2: Having the right solar battery

The solar battery is another essential factor.

We estimate that most solar homes only ever use around 25% of their solar system's electricity. This is because it is immediately returned to the grid unless your solar energy is used in your home as soon as it has been generated .

Batteries allow you to store your solar power later instead of selling it now at a low cost and having later to buy electricity at twice the cost from the grid.

This means that a typical solar home could up to 80-percent or more of its solar consumption.

Although some solar batteries provide fundamental features only, charging and discharging power with some control, others are increasingly 'intelligent.' These intelligent cylinders can communicate via the Internet of Things (IoT) with their owners and other household appliances.

And government subsidies will cover the cost of a solar panel, including solar panels.

Step 3: Energy efficiency is important for raising your home's overall energy output. Making your house smooth and safe is important, so it is an excellent place to start looking into solar hot water or a heat pump. Ask about your choices for your solar installer.

An important role is also played by investment in energy-efficient appliances – high-quality refrigerators, washing machines, dishwashers, air conditioners. You can set up devices (e.g., your washing machine) when your solar system generates more energy, even though you are not at home. This also involves timers .

Step 4: Put it together with smart devices It's perfect if they're super-efficient when it comes to appliances. When you can use smart, IoT-enabled apps, it's even better.

This means that they can be connected to the internet, programmed, and remotely operated via a smartphone and fully automated in some cases. A growing number of goods can also provide their owners with data on such items as energy usage.

Using Them or Lose Them

So, all the elements that you were getting. Now all of them must be integrated to form a home energy network that minimizes the need for the grid to purchase electricity.

Rule 1: Do not export your free solar energy. It is stated at the top of the post that you will have a solar system that is twice as big as your electricity consumption because you have enough solar power to export. The truth is that your feed-in tariff income is useful. But don't fool yourself, this isn't the only way to save.

You should always focus rather than sell your solar energy, even if you have a premium feed-in rate.

It's easy when you use your solar power. It's much more costly when you use grid electricity—using your solar power to run your machinery .

It is easy if you have a charger-- Using clever tools and timers to run your machines for sunny hours if you do not have a battery.

In the middle of the day, your washing machine is chopping off, the excess solar power generated by your panels will also charge your clever solar battery. Your solar power will be exported back to the grid until your battery is full.

At 6 pm, your battery's energy will fuel your lamps, television, and any other devices you use to cook dinner.

Rule 2: Off-peak grid power is a convenient backup choice. This illustrates how you operate in a perfect world with solar panels, batteries, and appliances. We realize, however, that the world is not perfect.

It may not always be feasible that your solar panels generate enough electricity to charge and operate your battery during the daytime. You can need to solve it, to change your energy usage to about 11pm-6am when energy from the grid is about 10c / kWh cheaper.

In winter, when sunlight is lower, and the power of your solarium can be decreased by up to two-thirds, this is most likely to happen.

If you have a battery, choose a low off-peak electricity contract. So recharging your battery over the night at off-peak rates via grid electricity does not cost much. You may also be able to use the credits you have received for the off-peak power on those sunny days .

Rule 3: Control your home often from the cloud Monitoring and smart devices play a major role in the management of the 0.0-bill household in both planned and unforeseen circumstances.

In one case, a house owner can track the amount of solar power on their batteries remotely from their smartphone during the day. If it is rainy and the amount of solar power generated is smaller than expected, they might connect to their previously programmed washing machine remotely and reschedule it until 11:30-the lowest possible alternative. It can also be automated.

Another scenario will require an IoT-enabled air conditioner to prepare a well-insulated house using free solar power automatically. It can only be triggered when the exterior temperature falls below a certain point. The owner may then turn off the air conditioner during the high evening, if the power costs more, by cooling the house during the day.

The core elements of the clever solar house may be modern digital assistants such as Amazon's Alexa and Google Home. You can handle them comfortably and speak to most or all of these appliances.

ADDITIONAL SUPPORT

The solar power systems are made of three main components: panels that can be polycrystalline or monocrystalline.

There is also a third form, cast mono, that's a combination of both the two main types of solar panel technology for residential homes.

If you have a mono or a poly-panel doesn't matter. The main thing is to buy a strong brand built on your roof for more than 25 years.

Good budget brands and good premium brands are available. There are, however, many 'no-name' garbage lines. Stop at all costs installing these modules.

An inverter, which can be either a string inverter (approximately the size of a case) or a microinverter which is around the size of a book on the back. It is the second main component of a solar power system.

A string inverter is mounted on a wall, and all the solar panels are connected to it; however, it has many advantages. The back of each solar panel is fitted with a microinverter.

A third alternative, power optimizers, which are a kind of hybrid between the two, is available.

Tip: Never mount a string inverter in full light.

Tip: You can select a shaded spot, a cool garage, or ask for a simple shade from the installer on the inverter. Clear, direct heat, as it burns, kills the inverters .

The inverters are responsible for converting the DC power solar panels into 230V AC power, which is what you use at home.

The inverter is the most likely part to fail within the first 10-15 years in solar system installation. It's because they're working hard all day long and tired out.

Tip: Up to 33-percent more panels can and should be mounted than the inverter is rated.

The racking/mounting is the third major part of a solar power system. It is the stable mounting for your roof rails and the installation of your solar panels.

A wide variety of racking brands are available.

Before you get solar power, the most important factor is how much energy you use in your home and when you use it.

When your panels produce solar electricity, then they are used in your home by appliances that export any excess solar power to the grid. For every kWh your plant exports to the grid, your electricity supplier will pay you a small price (around 7-20c).

The solar power generated by your device is better to use than to export it. Self-consumed power saves approximately 30 cents / kWh, since this fuel must not be purchased in the grid. Electricity exported receives a 'tariff feed' of approximately 7-20c per kWh.

Self-consuming solar energy is thus roughly 2-3x worth more than producing solar energy .

If you find yourself at home during the day or if you have pool pumps that work all day, you will take up to 65-percent of your self-consumption (with only exports of 35-percent).

When you don't stay home during the day, you typically use about 20% of the output of an appropriate installation for the solar system, bringing the easy payback to 6-8 years.

Keep in mind that your investment only offers a 12-15-percent return.

Avoid any solar company that offers a 100% self-consumption reimbursement. None of them have 100% self-consumption. To market it, the company is deceptive.

Tip: The amount of energy you use per month, or three months is only seen in your electricity bill. For a few weeks, before you get the quote, you can purchase an energy monitor (and get an electrician to install it). A successful installer will make maximum savings using this data to fit your solar panel better.

MORE TIPS ON INSTALLING THE SOLAR SYSTEM

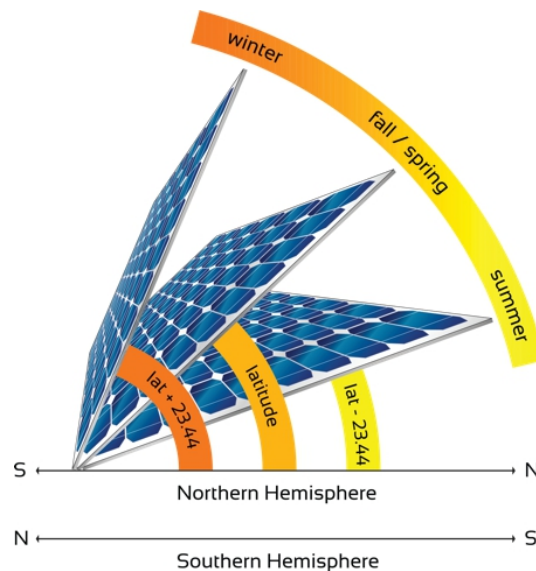

Panel Direction First – the absolute basics. The sun arises in the east and sets in the west. This means:

- East facing panels will peak in the morning in electricity production.
- In the late afternoon, west-facing panels will peak.
- Solar panels to the north peak about midday (which deliver the largest amount of energy in general).

A company will use more solar power with panels facing East and West to boost payback for their device before and after school/work.

Usually, it was true that a solar energy system was not worthwhile if you did not mount panels on a north face roof .

Now, solar systems' prices are dropping so fast, and you can receive a fantastic return on investment from panels to the east, west, or north, east, and west combinations.

In some cases, it often makes sense to have panels facing south – even though that is the last resort.

The ideal panel angle to optimize energy generated throughout the year is just a few degrees from your location: generally, the ideal angle whatever your roof creates, unless your roof is flat.

Tip: Flat roofs cause water pooling issues, and panels are dirty. One adequate way to prevent this is to use frameless panels that do not hang on the bottom, so that water typically runs over the bottom, rather than pooling the frame seal and swallowing it. Using frameless solar panels is also cheaper than building inclined frames on a flat roof.

Typical Solar Power System Payback Time

A well-designed solar system in Australia has a standard 4-7 year payback period.

This can vary significantly depending on your energy usage and device size. Still, the manufacturer will make a payback analysis for you to predict the payback period when you get quotes for solar power systems.

Tip: if you measure your use for electricity without half-hour usage data, you will get incentive estimates for bad self-consumption and energy consumption, and make sure you are satisfied with the reimbursement amount.

Do you Need these Batteries?

Energy storage batteries are fantastic. The calmness of being conscious that lighting, cooling, and other critical circuits are still available regardless of what happens in the grid is priceless.

There's big fun with batteries too. Really! Anything very special is that your house runs out of the plug.

Batteries also protect against the risks of rising energy prices and declining feed rates.

A well-sized, well-installed, and the optimized battery will minimize your grid consumption by up to 95%, almost preventing electricity and feeding you into the changes in tariffs. Of course, no-one knows what price and feed-in tariffs for energy would go. So you won't care if you've got a plug!

Nevertheless, these advantages are expensive.

An unsubsidized battery of that size has a standard payback period of around 15 years. Many batteries are guaranteed for ten years.

Compare this with a battery-free solar power plant. A good standard solar power system without a battery has an average return of about three to six years and is going to last about 25 years .

Thus, when you reach a state-based battery rebate, battery storage is not worth adding when you purchase batteries to save money. Our recommendation is to wait 2-5 years before investing in energy storage to lower battery costs.

Certainly, don't hesitate until you buy a solar power device, as that locks up high bills of energy per quarter in more years.

You don't even have to buy any specific battery preparation device.

Any of these can be purchased when purchasing your batteries, and installing the solar battery is extremely simple.

But if you want energy protection batteries, power price insurance against change, and exciting technology, go for it. Go for it.

Tip: Against logic, when the voltage falls, certain battery systems won't back up. If you want to make a backup, you have to state this in front, as it needs to be carefully planned and re-driven.

How do you Expect your Device to Pay? Economic Comprehension

Investing in a solar system should be taken seriously if you've got no debt and cash to find a place to go.

At present, a solar system installation offers a safe, tax-free return, which is far superior to bank interest rates or government bonds at the time of writing.

DIY Solar: What is it ?

DIY solar panels are not Scratch Panels. They apply instead to solar system kits that are shipped directly from a warehouse to your door. You will take care of the plant — either by constructing it yourself or by hiring a local contractor.

Installation of a solar panel DIY includes:

- Configure your custom solar system according to your specific energy requirements (including the size and number of solar panels)
- Authority and service firm for the filing of permits
- Purchase of solar panels, shelves, inverters, and other devices
- Mount and attach the solar panels to your storage device and inverter
- Programming and switching the device settings!

The construction of your solar system sounds like a big business, but many of our customers are pleased to say that it is simpler than it should be to start designing your solar system.

The majority of solar components are plug-and-play, which means that each cable snaps into a particular port. And because we supply a system kit, there's no question where the cable is going. Everything is labeled clearly, plug it in is everything you must do. It needs a few other basic skills to build your device. You ought to be willing, if you like, too:

- Dig holes and pour concrete (only for the floor mounting)
- Wire the machine to the power panel, the only point you need is to: Tighten up the bolts on the wrist
- Raise it to 75 pounds (recruit a buddy if necessary!),
- Dig holes and pour concrete, only for ground mountings. But that is all right: several of our clients chose to carry a licensed electrician in to the final power hook-up, typically charging several hundred dollars for 1-2 hours.

What are DIY Solar's Pros and Cons?

Some DIY solar panels are both beneficial and unfavorable to consider:

Pros:

- Save most labor costs, accounting for more than 50-percent of conventional solar panels.

- Build from scratch your solar electrical system to match your specific needs. Pick from a more diverse range of products and purchase just as much as possible (no single-size packages).

Speed up your time of reimbursement. If your system is installed and your federal solar tax credit is claimed, the grid-tie system will pay for itself in 3-6 years.

- Reduced unintended expense and flying surprises .

Cons:

- It's hard work. You are under control. To make your DIY solar dreams a reality, you must put in a lot of sweat stock. Completing the building is highly satisfying, but certain homeowners may not have time to undertake such a project.

- DIY solar projects cannot be approved by certain local building departments. Some jurisdictions require the construction of solar systems by a licensed professional, especially concerning off-grid systems.

- In the case of building a device, practitioners usually give a 5-10 year labor guarantee. If you're going to DIY, the standard of your job is your sole responsibility.

Learn how to Make your Solar Panels

Your solar panel requires some electrical capacity and is a time-consuming operation. However, learning how to install your PV panel is also a great way of understanding how solar power is made.

You must first understand how solar cells produce electricity before you can install your solar panels. The vast majority of the solar panels currently used consist of six inches square crystalline silicon wafers. The electrons in them continue to shift when the sun shines on the wafers. It is an electric current that passes by electrons .

A single, full solar panel would have 60 silicon wafers like the one used in rooftop solar energy systems. If your electricity needs are weak, you can also make smaller panels. The fundamental method for creating your solar panel goes the following once you buy individual solar cells (they could be bought online):

1. Prepare the panel's backrest. For their solar cells, most solar panel manufacturers use a wooden board as the foundation. You must bore holes so that the wires can move through for every cell.
2. Wire together the solar cells. This calls for some electrical work experience. Using a soldering iron to attach a wire to the solar cells and then link each of them.
3. Enter the backing cells. Put each solar cell individually onto the support, if necessary. In case a single cell is damaged or is not functioning properly, this makes it easier to replace it.

You have a working solar panel at this point, which can produce electricity when the sun shines. A solar panel is not, therefore, useful on its own. If you're trying to produce electricity to power devices in your home, your panel needs to be balanced by an inverter that transforms direct current (DC) from Sun to AC in most modern electronic devices.

You need a battery packing and charging controller in your DIY solar setup also to feature an autonomous off-grid system. The battery pack stores the energy excess, and the charging device controls the electricity flowing through the pump .

If the process is much more complicated if you want to create a solar panel system that will power your house, a typical solar PV system with a network link to your home would have about 20 solar panels that will each need to be wired up together and mounted onto your roof (or on your property at an unshaded terrain). Before your service plant can link your panels to the electric grid, a professional electrician must confirm the appropriate device construction.

Create your solar panel system or work with an installer Depending upon why you plan to install solar panels, whether you are becoming your solar panel system with a solar kit or working with an experienced solar installer.

DIY solar panels are compact and convenient for many off-grid applications for small-scale off-grid installations.

There are few inexpensive solar panel kits for sale that include any aspect of a solar DIY system you'll need. If you don't want to, you don't even have to create your solar panels. Constructing your panel system is a reasonable

choice if you want to install a small grid to power a trailer, RV, boat, or small house.

Working with a solar installer for a whole-home solar panel system will save both time and money in the long term when building a full-scale solar power plant in your house. For decades, some of the leading solar companies installed solar energy systems – an experience that no amount of online studies or DIY guidance can replicate. Your solar installer will also help you find funding opportunities and fill out the permits and applications required to run your solar system.

Study an immediate Solar Calculator's solar estimate to help you understand how much you can save by building a solar panel system for your home. You will have some quotes from local solar companies if you think about constructing your solar power system and meeting with an installer to see what it would cost. With EnergySage Solar Marketplace, you can conveniently compare the options of eligible installers in your region for free.

Tips on Building Solar Panels and Mounting Them

In the future, the construction of solar panels and photovoltaic systems will probably be simplified even further with the ongoing development of solar technology.

However, this doesn't mean that solar systems are a 5-step mechanism or should be attempted by anyone.

Installation of the solar system and what you should learn before you launch!

Because a solar plant requires working with panels and equipment that generate several hundred volts of electricity under the sun, some significant safety issues have to be addressed before installing solar panels or photovoltaic system components into your house .

Frequently, a professional must conduct the work in the field of solar installation, grants must be used, and strict electrical requirements must be met (often varying from one place to the next).

For this purpose, the construction of a solar power system also requires a lot of improvisation.

Do not, in any way, allow you to disregard your municipality's regulations, laws, specifications, and instructions for building solar panels or solar energy systems.

Solar Panels & Solar System Installation

1. You must first ensure that your solar panel is solid enough for the installation of the solar panel and to support weight in the roof or wherever you want. There is no need to install solar panels on an inbound roof, and you will have to restore more money at the end of the day.

2. For solar roofing tiles to calculate your roof dimensions to make sure that your solar panels (the entire solar panel) fit into the space available, the next thing you have to do in the process of installing solar panels. You will want to consider using an area where more panels can be installed in the future while building solar panels. Ideally, solar panels will be mounted on a roof facing the direction in which the sun rises. If the sun rises in your sector, then to optimize exposure, your panels will face east. Make sure that the roof is shaded by other homes, structures, wooden trees, etc. One important thing about installing solar panels is to prevent the solar panel from running with only one solar panel in the shade. Be sure that the shade will not come with a change in the seasons or the potential growth of your neighborhood even when you add solar panels. Attach solar panels at the edge of the roof no closer than 12" and the eaves 16'.

3. You must place brackets on sloped roofs or mount rails on flat roofs before installing solar panels. In-home improvements or solar shops, solar panel mounts can be purchased. Standoffs for the brackets or bars, not just the shaving, must be protected in the bathroom. Solar mount brackets are used on sloping roofs, but the slope must be positioned in such a way that the panel is exposed to the sun directly. In the solar installation, a rail mounting system is used to place the panel at any angle of your choosing. To ensure that the voltage output remains the same, it's necessary to maintain all the solar panels in the same angle and height (even with the roof slope changes). Please use roof sealant, so that no rainwater will flow through the hole in your roof when you hang the brackets or the rail mounting board. Follow the directions given with the brackets or rail

system to make sure your panel system is designed according to the recommendations of the manufacturer .

4. Then add your solar panels to your roof, position them on the brackets or mount rail system and attach them to the bracket or rail system. Make sure you don't unintentionally fall off very sloped roofs while building solar panels until you can mount them.

5. If your solar panel is full and your panels are stable, you must link them together to generate electricity. Making sure that all the wires (wrapped with a black electric band) are correctly shielded and waterproofed. To order to avoid shocks, the ground wire from the assembly equipment must always be attached to the ground during solar installation.

6. The ducts must be run under the panels, to the junction box, to the site side, and the first photovoltaic part inside the device – usually the DC disconnection. The duct is linked and aligned.

You have to use "cable" consisting of three wires for the solar power installation: negative, positive, and coil wire. The real roof will not be reached by any wire. To shield them from heat, sun, and other conditions, mount a conduit on all wires coming out of your panels.

7. Now configure all your photovoltaic components as directed by the manufacturer (but do not attach them yet)—Mount in a garage or outbuilding your inverter and the other photovoltaic parts. Make sure the area is dry, well ventilated, and space is not overly hot or cold. This is particularly important when your battery bank is involved. In reality, if there's any wind, you can use a battery box to prevent the weather from shifting around your entire battery bank. A battery box is also required to prevent accidental electric shock to children and pets.

8. The next stage will be to run the power from your inverter into the AC breaker and other device components of your home. To do so, turn off the key disconnecter and de-energize both AC and DC power sources.

Link to your AC breaker panel your inverter; Please connect the photovoltaic wires before the main DC connects and other photovoltaic network components. Link the main DC to the inverter then.

You should turn on your disconnecting switches, and DC / AC disconnects and energy will be transmitted from the AC breaker panel to all power loads inside your home after you do this and ensure that your device is secure by having a qualified electrician to check and verify that everything works properly.

Using a pipe to protect against shock and short circuits when cabling through walls. Using a PV conduit with water-resistant fittings or a conduit seal to preserve the water out for outdoor wiring .

Any time you exchange energy with your electric utility, you will also have the chance to install, next to your main solar power box, a second smaller panel box, with a simple shut-off switch to make it easy to disconnect the electricity from the solar panel. The safety procedure in solar installations is very normal and typically necessary.

The breaker used for the solar feed shall not exceed 20% of the service size of the AC breaker plate. And if the energy of your home is 100 amps, your breaker size is limited to 20 amps. You may need to extend your home's electrical capacity by 200 amps or more if you add Solar Panels and a PV system with more amps than that.

Here we list a couple of alternate ways to save even more money by actually dealing with some of the most costly and "legally difficult" aspects of solar power plants.

When you are not going over the difficulties of designing and installing solar panels on your house, you can always put them in the backyard or on your balcony if the solar panel installation is too work-intensive. It means that you have a stand or adjustable support behind your doors.

Different regions, however, do have different guidelines. Some areas include the use of a fence or an 8-foot higher pole mount to shield any sun panels not installed on the roof from the public. Find out what is needed in your area and do your homework before you do it .

Plugs or Panels?

You can plug devices straight into the inverter if you do not want to attach straight to your home's AC breaker panel. Fit a device that can be installed in a convenient box of "direct" power supply outlets (plugs) with appliances, toasters, lamps, etc.

APPLICATION OF SOLAR POWER SYSTEM

Solar Energy Benefits

Do you know that the one-hour energy supply from the sun will fulfill the World's energy needs for one year? The sun, without doubt, is a strong source of energy, and even though we can only capture a fraction of this energy, it can still make a significant difference for the World by using solar panels.

While it has been generally and widely criticized for being expensive or unreliable, solar energy now has proven to be extremely useful – not just for the environment but also for private businesses.

The solar energy sources are the key sources for increasing families thanks to the solar panel grants available and the highly affordable rates on the market. The technology has been dramatically improved in recent years and complemented by solar battery storage systems, which turn solar into a much more renewable energy source.

- Clean, sustainable. Many fuel sources requiring exploration must be removed and exhausted from the earth.
- Low-keeping. After installing solar panels and optimizing their performance, they need very little daily maintenance.
- Calm. Solar panels make no noise as the sunlight is turned into fuel .
- Good to the community. Solar and personal solar power plants do not produce emissions or other adverse environmental effects.
- Being cheaper.
- Check the details
- Providing clean energy, the solar energy supply is 100% a sustainable source of renewable energy. This reduces reliance on oil, coal, and gas for the production of electricity. Such fossil fuels are responsible for toxic pollution, impacting air, water, and soil quality. The World will lose more plant and animal species for extinction between 2000 and 2065 than the previous 65 million years combined.

This is amazing and is mainly caused by greenhouse gasses from fossil fuels.

Solar energy does not, however, create emissions. The plentiful sun power generates a limitless energy source that does not destroy or damage the ozone layer from the environment. The sustainability of the earth, the protection of energy supply that is not renewable, and the climate are an investment in residential solar power systems.

The most significant thing is that solar energy is a true source of renewable energies, among all the advantages of solar panels. It is available every day and can be harnessed in all regions of the World. Unlike some other sources of electricity, we cannot run out of solar fuel. Sunlight should be available as long as we have the sun, meaning that we have at least 5 billion years of sunlight if the sun is going to die, according to scientists .

Do you give electricity independence and power? Our grid needs to be revamped to meet the ever-growing needs of a plugged society.

The installation of a home-built battery powered by solar panels enables households to store plenty of energy to operate their homes during peak hours.

Home batteries and solar panels of Brightbox(™) are also a viable solution for rolling blackouts implemented by wildfire prevention companies. The antiquated infrastructure today causes power outages for even communities not directly affected by wildfires. This summer, all PG&E clients will lose control, impacting as many as 16 million people.

Your home is powered by solar roofs during the day and by battery energy during the night with a residential solar panel. You achieve energy independence by installing solar panels.

Solar panels are becoming more affordable, more available, more robust, and more effective. If the power goes down or the next storm hits, they provide households with peace of mind and energy efficiency. Sunrun's home-built Brightbox battery system replenishes sun-generated energy and reduces the pain, confusion, and expense of refueling a gas or diesel generator. The clean and quiet Brightbox is a preferred alternative to a conventional backup generator for many families.

If you face that home energy expenses, home solar panels will compensate for your expenses. You can save on your current energy bill .

Cloudy days will also save because the sun is releasing energy by bright, cloudy skies. Even in colder, rainy climates, Solar provides all year long productivity and economy. Some solar panels produce more electricity than your home consumes, depending on their scale, efficiency, and orientation relative to the sun. This will raise your energy bill to zero monthly. If your solar energy system produces excess electricity in certain places, you will potentially apply for a rebate. Check the solar energy guidelines for your region.

Each year, the majority of utility bills are increasing. Customers are paying stable prices for the next 25 years with Sunrun's solar service contract.

When you fulfill some of your energy requirements with the electricity produced by your solar panel, your energy bills will decrease. How much you save on your bill depends on the scale of the solar system and the electricity or heat usage. There is a chance to earn surplus energy payments that you sell back into the system, not just savings on the power bill, but when you generate more energy than you use (being mindful that the grid is associated with the solar panel system).

Tax Benefit Qualification

The provision of local, state, and federal tax cuts is another aspect that increases the affordability of solar panels.

The cost has plummeted. In recent years, solar prices have decreased significantly by over 70-percent in the previous decade. You're also going to save money on repairs because there are no moving parts to break down. However, the cost of solar home batteries has also decreased considerably.

Solar energy can be used for various applications. Different applications The power (photovoltaics) or heat (solar thermal) can be produced. Solar power can be used for generating electricity in areas that have no grid connection, for distilling water in areas that have small clean water sources and for power satellites in space. Solar energy can be incorporated into construction materials. Sharp launched direct solar windows not long ago.

In the solar energy industry, technology is continually going forward, and future developments must be stepped up. Quantum physics and nanotechnology advances will theoretically increase solar panel performance and the electrical input of solar energy systems by double or even triple.

The effect of solar energy on the atmosphere is less negative than any other form of energy on the atmosphere. It is not greenhouse gas produced and does not contaminate the water. In contrast to nuclear power plants, for example, that requires 20 times less water for their maintenance. It needs very little water. The development of solar energy does not produce any noise, a major advantage because a majority of solar systems, such as domestic solar panels, are in urban areas .

The generation of solar energy does not generate noise pollution, which is an important thing for urban plants. This also does not produce any waste, because its lifespan is much longer than other power generation systems and is no maintenance necessary. However, in severe weather conditions, solar panels are designed to withstand the effects of the climate.

The loss of energy during transport and distribution increased as the gap between production and supply points increased, leading to a reduction of energy during long-distance transport. While these losses are not very large, they affect the deployment efficiency in densely populated areas.

The distances on the roofs, however, are dynamically decreased, increasing the performance of the electrical grid by the individual installation of photovoltaic panels.

Solar Energy is Applicable All Over the World

Solar energy can be used everywhere as long as sunlight is present. This is quite useful in remote regions with no other electricity source. There are a huge number of people worldwide who have no electricity connection.

In these countries, independent solar systems could be used, and the lives of millions of people enhanced. Solar energy will be used to power spacecraft and boats .

Increased Grid Protection

When many power plants are scattered, the grid is less vulnerable to black-outs. A system with high solar energy penetration has thousands of large-scale electricity storage centers. In the case of congestion, natural or human disasters, this increases the reliability of the system.

In the case of regular black-out and voltage drops, this is a significant indirect advantage that has a direct effect on energy grid performance. The capacity of thousands or even millions of energy production centers to integrate solar energy increases power grid protection against overloads or fires in transformer substations.

Work Creation

There are various benefits of solar energy. Job creation is another one. The construction of panels is a significant proportion of the costs associated with solar systems. It helps to build local jobs. The use of solar systems improves the economy and affects the local environment positively.

APPLICATIONS IN HOMES

A small solar electric system (such as photovoltaic or PV) can generate energy for home or office without pollution and efficiency. To produce electricity, PV systems use both direct and distributed sunlight. The more direct solar power it generates, however, that reaches the photovoltaic system.

Solar Water Heaters



Solar water heaters may be a good alternative to traditional gas or electric versions.

Solar panels thermally provide water to a holding tank.

A solar water heater consists of a blacked, flat metal plate collector with a metal tube that faces the sun's general direction. The collector has an overlay cover of clear glass and a thermal insulation layer underneath.

The metal tubing of the collector is linked or connected to a hot water tank on rainy days via a drain. The collector absorbs solar radiation and converts the heat to water, which circulates either through gravity or pumps through the tube.

This hot water is pumped via the corresponding metal tubing to the storage tank. In hotels, guest houses, tourism and canteens, schools, canteens, and domestic and industrial facilities, this water heating system is frequently used.

Solar Outdoor Lights

Solar lights use solar panels to turn sunlight into electricity – for example, sunlight solar safety lamps or solar floodlights. This electricity is stored in special batteries by outdoor solar lights. In the evening, these lights are powered by batteries.

Sunny places are appropriate for both self-contained units, such as solar security lights and floodlights, and separate solar power panel systems. Check that the manufacturer offers new batteries and bulbs before purchasing a solar lighting device. Consider the landscaping of your house, too. Shade can also affect battery charging and the output of solar lights from trees and buildings.

Solar Cookers

Whether you are building a pre-assembled device or buying it, solar furnaces are becoming increasingly popular.

Like an electric crockpot, a slow cooker is a solar oven. A solar oven heats food at relatively low-temperatures for several hours (eight to 10 depending on the recipe). The solar reflectors channel solar energy into a special chamber. Once again, in the form of sunlight, the fuel supply is readily available.

A wide range of carburizes is used for cooking purposes, including coal, kerosene, firewood, dung cakes, and farm waste. As a result of the energy crisis, their supply (wood, biomass, kerosene, cooking gas) is either diminishing or is too precious for cooking (cow dung may best be used as soil fertility manure). This included the use of solar energy and the creation of solar cookers for cooking purposes. A plain solar box is a solar cooker style flat plate box.

It consists of a well-insulated wooden box made of metal that is inside blackened. The solar radiation inside the chamber is low. As greater radiation from the higher wave can't move through the glass cover, it minimizes the re-radiation from the blackened interior through the two glass coverings to the outside, which decreases the thermal loss.

Via airtight, the box eliminates the thermal loss due to convection. To accomplish this, a rubber strip between the top deck and the box provides

mini-control to reduce the heat lost by conduction, and the area between the blackened tray and the outer cover of the box is often filled with an unpleasant material such as glass wool, paddy husk, etc. In the solar box are put the cooking pots blackened from above.

The uncooked food is cooked by the heat energy produced by a decreased solar box temperature. By having a mirror for the flat reflector, the region of a solar cooker can be expanded. The cooker box generates a 15 to 25°C increase in temperature when the reflector is set to reflect the sun's rays into the pot .

The solar cooker does not need power, attention, and waste and excess of food. And the biggest benefit is that cooked food's nutritious value is high, as vita tastings and natural tastes are not ruined. The solar cooker needs no food.

Solar cooker repair is negligible, The main drawback of the solar cooker is that it is not possible to cook food at night, gloomy or short notice. Cooking takes comparatively more time, and a solar cooker cannot cook chapatis.

Small solar devices compared with large appliances such as refrigerators, washing machines, and HVAC systems, our rechargeable electronic devices may seem inefficient. However, it indicates that they use more energy than we think to take the entire energy expense of our use of these tools into account. The easiest, cost-effective, and efficient way to expose your family to the benefits of solar power is through a solar-powered phone and tablet charger.

Solar Buildings Heating

Solar energy may be used in several ways as a resource for the heating of buildings:

A) Solar radiation is received directly through large windows facing south as an aspect of the building itself, i.e., solar energy .

B) Use of separate solar collectors to heat water or air or storage facilities to store solar energy captured during night and daytime for use in inclement weather conditions.

As heat is needed by the building from such collectors or storage devices, traditional equipment such as fans, ducts, air ventilation systems, pump

radiators, and hot-air registers, etc., transfers the heat to warm up a building's living room.

If no heat is required in the house, the heated air or water may be transferred from the collector to the heat storage system, such as the isolated tank or other material for heat storage. A gas, oil, or electricity supply system is needed as a backup system for inclement days.

Solar furnaces: High-temperatures are produced in a solar furnace by focusing the solar radiations into an exemplar using a variety of heliostats (turnable mirrors). The solar furnace is used to investigate the proper characteristics of ceramics in laboratories with flames and electrical currents at extremely high-temperatures above the limit.

Heating can be achieved without any noise, and by adjusting the location of the material in focus, you can easily regulate the temperature. For operations involving metallurgy, it is particularly useful. On an open specimen, different property measurements are possible. Nitric acid and air fertilizers are an important future application of solar furnaces.

APPLICATION IN VEHICLES

Solar-powered cars have come to the fore due to a renewed interest in green and sustainable energy systems. Many car companies are producing solar vehicles, and the automotive industry is evolving.

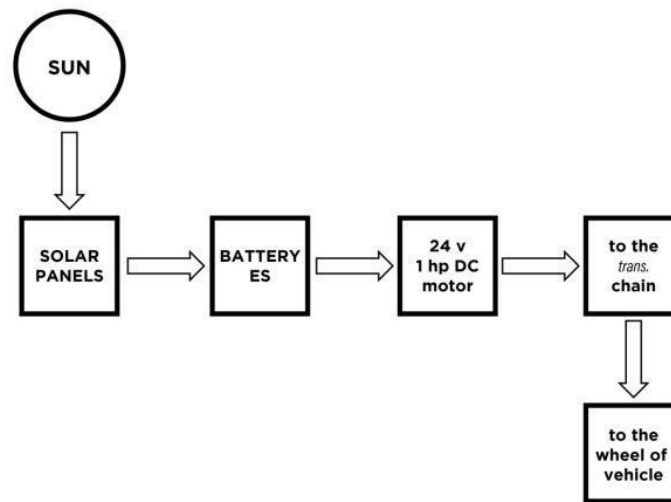

Solar cars are solar-powered hybrid vehicles. Photovoltaic cells are used to convert energy into electricity from sunlight. Such vehicles can store some solar energy and can also be run easily in the evening or without direct sunlight. Solar cars not only add to the emissions in the atmosphere but also the emission of noise.

Many solar-powered car designs are currently being evaluated. In the production of hybrid solar cars are several big players and startups. The demand for solar cars is expected to reach USD 1-billion by 2020 if figures are to be believed. Automotive companies are already taking advantage of the popularity and building solar automotive kits. These kits will support cars with solar energy over long distances .

However, there are design restrictions for solar cars as esthetics must also be taken into account to fit solar panels. Some solar cars are therefore designed to run so far, rather than for everyday use, in solar car races.

The best solar car currently available is Sunswift IV. This car was planned for solar racing by students from New South Wales University. The car uses equipment similar to that used in the cycling, aerospace and automotive industries, and a variation of it.

To date, however, none of the vehicles is built to rely solely on solar energy.

A solar car uses solar energy to recharge its batteries with the help of solar panels. The cars are based on photovoltaic cells that help them convert electricity from sunlight.

Technically the photovoltaic cells are hit by the sunlight images, and the electrons are excited. This permits an electron flow that produces electrical processing currently. This electric power is then used to drive the vehicle as a "steam."

- Save money on petrol
- Is renewable
- No extra costs except for the replacement of batteries
- Does not cause noise pollution or air pollution
- There are several benefits of using solar vehicles.

APPLICATION IN INDUSTRIES

Solar distillation: There is a shortage of drinking water in arid semi- or coastal regions. The abundance of sunlight in these areas can be used by the solar distillation cycle for turning salt water into potable distilled water. Solar radiation is allowed into a flaky blackened tank containing saline water through a clear, air-tight glass cover.

Solar radiation is absorbed and converted into heat from the surface of the black soil, which causes the water to evaporate from the saltwater (the impure saline a reservoir) by passage through the cover. The emitted vapors are condensed into clean water inside the cool roof.

The water is filtered and flows down the sloping roof and collected into the floors and a drinking water tank in areas of shortage and classrooms, school scientists, defense laboratories and gas pumps, hospitals, and the pharmaceutical industry. The water is filtered. The distilled water costs per liter of this device are lower than those produced from distilling water by other electric power processes.

Pumping of solar energy: in solar pumping, solar power for irrigation purposes is used to pump water. The water pumping requirement is greatest in hot summer months, and this method is best suited for watering purposes, coinciding with the increase in solar radiation over this time. During times of bad weather when solar radiation is low, the water pump reduction requirements are also relatively low, as there are also small transpiration losses from crops.

Solar drying of agricultural produce and animals: This is a traditional method for the drying of agricultural and animal products with the use of solar energy. The agricultural products are dried in a simple cabinet dryer consisting of a box separated from the floor, coating black on the inside, and a clean sheet of glass covered in a reclined layer.

Ventilation trousers are installed at the base and top of the sides to facilitate airflow through the drying material on drilled trays within the cabinet. These drilled trays or racks have been crafted carefully to allow controlled solar exposure.

Solar drying improves fruit quality, particularly of fruit, as the concentrated sugar content increases when it is desiccated. Soft fruits are typically especially vulnerable to attack by the insect as dryness increases in sugar content. Still, fast-drying saves time in a fruit dryer — which reduces the chances of an attack by insects.

In addition to a lot of open space and manual labor for material handling, the current method of chilly drying by spreading them on the floor is difficult to preserve the consistency and taste until a checked atmosphere is dried. Sun-dried items are most frequently ruined by unexpected showers, storms of dust, or birds. Furthermore, studies indicate that in sun-dried chilies, it is not possible to achieve a very low humidity .

This leads to fungi and bacteria that attack chilies. The commodity is over-dried, and consistency is lost in sun-drying sometimes. Some of these drawbacks are solved by solar power driers.

Botanical chips, berseems, corn and paddy, ginger, peas, pumpkin, cashew nuts, wood and dairy, and tobacco cure are other types of agricultural products which are commonly solar-trough. A sprinkling of milk drying and drying of fish are examples of solar-dried animal produce.

Solar Power Generation: Photovoltaic cells may be used to generate electricity or electricity directly from solar energy. The PV cell is a power converter that converts photons from sunlight to electricity directly. It consists of semiconductors that absorb the photons taken from the sun and emit free high-energy electrons.

Such high-energy electrons are stimulated to migrate from the semiconductor into useful work by an electrical field. This electrical field is normally given in photovoltaic cells by a p-n interconnection of materials with different electrical properties. There are various production techniques for achieving optimum productivity in these cells.

These cells are arranged as cell modules in parallel or series com. Such modules have high-efficiency, no fuel costs, low maintenance costs, length, modularity, modularity, pollution-free operation, etc. Photovoltaic cells were used to run irrigation pumps, rail crossing warnings, traffic lines, road emergency call systems, automated meteorological stations, etc. in areas where it is difficult to work.

They are also used as portable power sources for television sets, monitors, watches, readers of monitors, batteries and satellites, etc., and as weather forecasting systems. Solar thermal cell output means the conversion of solar energy into electricity using thermal energy for irrigation systems, drinking water supply, and for supplies of electricity in rural areas i.e., in road lights, etc. Solar energy is used in this process first to heat a working substance, gas, water, or some other volatile substance. This heat energy is then converted into a turbine's mechanical energy. Finally, this mechanical energy transforms into electrical energy by a convenient generator coupled with a turbine.

Power production through solar ponds: a solar pond is a natural or artificial body of water used to capture, absorb, and store solar radiation as heat. This is highly shallow (5-10 cm deep) and has a bottom absorbent by radiation (black plastic). It has a curved fiberglass cover, which allows solar radiation to be accessed and decreases radiation losses and convection (air movement). Heat loss in the field is reduced by the insulation of the bed beneath the bath.

Solar ponds use water to absorb and store solar energy, which is used to produce power through the conduction of turbines that evaporate an organic fluid with a low boiling point for different applications, such as spatial heating, industrial process heating, and electricity .

Solar Green Houses: A greenhouse is a device that uses transparent (glass or plastic) materials to generate solar radiant energy. It provides temperature management, heating, cooling, and ventilation equipment inside the greenhouse.

The greenhouse glazing can be exposed to solar radiation, but the thermal radiations caused by objects inside the house cannot escape the glazed surface. In the green room, the radiation is then contained, and the temperature increases.

The greenhouse is closed, and the air in the greenhouse is enhanced with CO₂ as the greenhouse air is not combined with the ambient air. The loss of humidity due to a small spiral Tran is minimized. All of this leads to plant growth during the day and the night and throughout the entire year.

SOLAR POWER FOR TELECOMMUNICATION NETWORKS

Another use for solar photovoltaic is solar power for telecommunication networks. For areas that do not have a grid, even in those areas where the grid is supported, the BTS telecommunications towers have a diesel power supply. Electricity generator operating costs are very high. Clean energy is the perfect alternative for diesel back-up. Such systems can be hybrid (wind and solar), where there is water. Most telecommunications companies have solar systems built and have been highly pleased, and others are also preparing to purchase solar systems.

APPLICATION IN BOATS

Maritime solar panels are solar panels supplying energy from the sun to power the ship in a combination of modes and use this energy to power the boat. One of the most common applications of these naval solar panels is that the battery is used to repair or keep the boat as a back-up for a battery at any time.

A marine solar panel can likewise be used for the addition of modern power to the hull. Most companies, while making it more accessible types and dimensions, make these things extremely convenient to use and attach to any electric device boats have. The ultimate point is a massive solar panel installed off your boat's side, as there is no room! These solar panels can be mounted in various ways, including on tops of the shade and other outside parts of the ships.

The key advantage The key object that the sailor uses solar is the significant fuel savings. Solar energy is far more affordable than the power produced by a combustible generator.

The sound level is the second aspect. This is vital for a quiet life, while you are at sea, to the lowest levels of sound. While driving your boat or vessel, a rising generator sends vibration. The safest marine solar panels are calm.

The marine solar panels do the related task of producing energy quickly and effectively and avoid unnecessary sound pollution .

The additional gain from the solar panels on your boat is that you can charge the battery of your yacht while you do not stay on the shore. This involves a sailor who can secure a boat in the middle of the sea and focus on something such as scuba diving, reading, or fishing.

Mechanism Marine solar panels, like other solar panels, work by controlling and regulating energy from the sun (in this case, a boat). The sun's light catches the solar plates and then begins the electrons on the surface of the plate. Then, when the electrons are triggered, they continue to produce DC charges. This energy is then stored in the batteries connected to the solar panels on which it is ready for use.

Solar panels have an extended operational life. Mostly, you will be served 20 years by decent quality naval solar panels. However, at almost five years, some of the adjustable marine panels are said to have a much smaller length. All this depends, but regular solar panels are solid and are always sponsored by the company and brand you buy. However, if you need an adjustable solar panel, it's worth it entirely — as long as you know you can keep it to rescue in five to 10 years.

When it is connected to your trendy electric boat, Marine solar panels work best. It should be noted that when the modern boat system is linked with the solar panels, this approach works better. It means that the balanced electrical grid on the boat will come to an end if the solar panels are completely ineffective (as though the sun is not done for many days). However, you can keep the money a long way, even though both systems are installed, by not getting more and more petrol.

Marine solar panels will keep your money with a long-lasting and efficient power supply and battery for your boat. After all, renewable energy is such an extraordinary source.

APPLICATION IN CABINS



You also have a little land in the forest and have always dreamt of building a cabin to escape life's pressures. But in the forest, it is a way out, down a winding gravel path, with no access to the electricity grid. However, does that mean that you cannot have the best of both worlds-your lives in the city and your holiday cabin in the forest? So how can the laptop, lamps, and other electronic equipment be powered? The answer is to have a solar power system and turn your trip into a solar cabin!

It is very feasible that you won't be able to fuel items such as a full-sized resident heater/oven and an electric heating system. A propane tank is also the most powerful solar cabin, and we encourage clients to include propane in their off-grid energy profile. In contrast with diesel or petrol to a generator, propane is a fairly clean source of fuel. Instead of fuel, propane can be used to drive both a stove/backroom and a refrigerator. A wood stove or propane may be used to heat your cabin as fuel. Heating is not a concern for you if you already have a wood stove or a fire spot. Even if you

don't, propane is a great way to make the solar system as cozy as your favorite pillow!

MAINTENANCE OF A SOLAR POWER SYSTEM

In general, solar panels need little maintenance to operate. The only thing that they need is a daily light cleaning to ensure that the sun is not obstructing soil, leaves, and other waste. The only time you need more work during heavy snowfall times is when your panels start to decrease their energy production.

You're lucky if your panels are inclined: rainfall immediately clears the debris on it. However, it is essential to clean them manually during the dry season or for long periods without rain. It is usually advisable to clean the solar panel two or four times a year. The good news is that it doesn't take a lot of time. What you need is a blower with the leaves or a simple jar spray with a garden plate.

After a heavy snowfall in winter, you might have to clean your windows. Make sure it's tender if you are using water to remove snow. A squeegee with a long handle may be used as well. Never use warm water to clean the panels of snow. The panels are of tempered glass, and they can be broken by the drastic difference in temperature between hot water and cold waters.

Normally with solar panels, very little service is needed for solar panel operation. They last between 25-30 years without maintenance and are very long-lasting. The only maintenance you need is to wash them two or four times in the year, clean of dirt and dust, which you can easily do with a garden brush. The simple cleaning routine ensures that the sun will brightly shine on the window, optimizing energy for electricity. Watch for panels to drop leaves or snow so that you can delete them as soon as possible.

Reputable solar power companies provide guarantees on their solar panels, which last for at least 15-25 years after installation.

Solar Power Warranties

The assurance will ensure that the solar panel production during this period is not below a certain amount. Solar panel guarantees can be passed to new owners if you sell your house.

Overall, for the first 25 years of the panel's existence, the peak solar power production is not projected to decline by 85-percent. Look for solar companies that can ensure the output standard.

Solar panels will help you save on energy bills, but they must be maintained well, and a reliable guarantee must be obtained. Find out how many solar panels are required for your home.

Solar panels are designed for long-lasting use. PV systems deliver high-quality solar panel systems to withstand any kind of environment, from wind and rain to snow and more. You would be delighted to learn that hail is well protected against by the solar panels. They are, of course, not 100% permanent; earthquakes, hurricanes, tornadoes, or lightning may be destroyed on rare occasions. But you can get any damaged panels fixed or replaced as long as you have a strong guarantee and your panels are protected by homeowners' insurance. Ironically speaking, heat is the type of weather most frequently affecting panels. If the temperature is above 90oC, the panels lose about 1-percent per degree of output. In the course of daily solar power maintenance, however, you can take your solar system periodically and track loose links, mounting equipment, and panels by elevating it to a few centimeters above the earth or roof.

Clear every debris at the base of the brackets and connections of the solar panel. It could deteriorate the surface that causes leaks on the roof if too much junk is brought in here. This is a very necessary aspect of the care and cleaning of a solar panel.

When you see the dirt, grime, and other organic things like bird waste that have accumulated on your solar panels, wash them gently in the cooler hours of the day with dish soap. Don't put too much pressure (when a solar system is cleaned), or you could destroy it—installed in dust-dependent locations solar panels that require increased inspection and maintenance of solar panels.

Solar maintenance involves cleaning and corrosion management of the battery terminals periodically. Apply petroleum jelly or industrial sealant on terminals to prevent corrosion from beginning.

To test what the solar system makes, use a multimeter twice a year to ensure that it has not fallen significantly from the previous year. If it does, then you can remedy the problem and repair it .

Occasionally, perform repairs in the solar panel by checking cracks or cells within the solar panel. You never know when a fleeing aircraft or a small comet is going to fall from the sky. All right, it could be a big bird?

Keep your batteries in a room-temperature and moderate setting. At lower temperatures, batteries lose storage power but start degrading at higher temperatures. You will preferably keep your battery bank between 65 ° and 75 ° F. Necessary solar maintenance is very important.

For daily solar energy maintenance, charge your batteries once per month to completely equalize your bank batteries and avoid any worsening of weaker batteries. If you use the amp-hour meter, you can test that your batteries are fully charged.

The inspection of home-made solar panel seals for leaks or wear is a very important aspect of maintaining a solar system. Re-seal the panels with clear, flexible exterior silicone if necessary, with all water-proof seals.

MONITORING YOUR SOLAR POWER SYSTEM

With the integration of a solar panel monitoring system, you can track the amount of energy that is generated and how much is generated in your panels every day. This lets you see how various external factors affect the performance of your panels and how well they sustain their performance throughout their lives. The control system will also inform you if a panel breaks or fails to fix or remove it.

A solar panel monitoring system is the best way to ensure the best performance of your project. Monitoring systems provide information on the solar system's electrical efficiency. This information can be monitored over time for the measurement of panel degradation. Monitoring devices often have a warning if the fault or harm occurs.

Health is of utmost importance, as are all matters concerning your solar system. You can hold and clean your panels from the ground almost always with a tube. Yet when climbing on your roof, you have to get to your tables.

If surfaces are slippery or wet, intense attention should be paid. Do not, at any point, impact the system's electrical components. Before trying to get on your Solar roof systems, make sure you protect your ladder properly so that it will last several years. To date, solar panels with less sophisticated technology have nevertheless performed exceptionally well in their first-generation!

CONCLUSION

Repairing and Replacing Solar Panels

It is best to employ a specialist if your panels need to be fixed or replaced. Call your solar company when you lose productivity and are still subject to a performance/power production guarantee. You must either assign someone to analyze the situation and patch or uninstall the panels. If you have sustained physical damage to your panels, it is also protected by a different product warranty or insurance. Find out whether and how the appeals panels are being covered and who to call. Do not attempt to mount or restore solar panels, either, unless you have a home solar system experience.

- Keep solar panels out of shade as energy output is inefficient if they are not able to receive any sunlight. More detail on solar panel maintenance.
- Maintain oversight of the solar panels and ensure that the inverters blink green lights. If you don't flash, you lose money by turning off your energy use.
- Record everyday efficiency to enhance the maintenance of solar panels. It is important to record how much electricity is produced every day at a consistent time and to note the dates on which it is quite cloudy. There are some contradictory results .
- Monitoring systems let you see exactly how much you support the environment and how much CO₂ you are emitting in the atmosphere. (The supplier might give you the best monitoring system for your solar panels.) You will also know how much of the feed-in tariff can be helpful.
- You can see details on the wall-mounted display of your solar panels when at home.
- You can add automatic cleaners that act like sprinklers and even schedule customs with solar panel cleaners if you do not have the time to clean solar panels.
- Luckily, solar-powered panels might not be sufficient because they have moving parts that may be damaged by rust or breakdown.

Many home holders are worried about weather conditions that damage their panels or roof. Cleaning tips for solar panel cleaning In all types of climates, solar systems are installed. Regardless of whether you live in harsh winters, heavy storms, coastal conditions, or heat waves – the solar system can and will do anything.

It is important that your panels stay clear of waste or snow, to ensure optimum efficiency for your panels. There are ways to ensure that your panels generate maximum energy.

- A leaf blower
- A simple, quick rinse with the panel can be used for trees, birds and generally make dust
- Also light rain can be used for the construction of a panel to wash away (rain won't clean up the flat panels usually).

To clear a hard layer of snow:

- Throw a football to wipe out snow loss (which may inevitably lead to a lost football)
- Using the leaf blower
- Panel Cleaning Kits for solar panels come in very useful for washing. The package includes a biodegradable soap, a snack, and a small brush with a longer handle. Combine the soap with water in the bowl. The bottle is given instructions. Then drop the brush in your bucket and start cleaning the solar panels gently. You can remove grime or dirt on the tiles with plain water or a soft brush.
- It's never been easier to clean solar panels! If dirty or muddy, clean the solar panels so that any dirt is easily washable from them.
- None of your solar panel cleaning with an absorbent sponge or soap because you can crack the glass. A soft rag or biodegradable soap is the perfect way to purify solar panels.
- It is important that harsh materials are not used when cleaning solar panels because they can cause damage and the repair of solar panels is costly.
- You might only pull a panel with a hose to remove dirt if you clean regularly .

- Few calls for the installation of solar panels.
- Use a long-handled wiper to clean the panels while you stand on the ground to ensure your health and the healthiness of others.
- If you have to climb on the roof, be careful as soon as cleaning starts, the roof will be slippery, and you might fall off when you get down.
- Look out also for solar panels dirt to ensure that it doesn't build-up, as sunlight can be better absorbed when dirt free.
- Many people ask, do you need cleaning solar panels? -- Yes, is the reply. You can be used weekly or monthly to clean solar panels, depending on the type of panel you have. For solar panel cleaning, your solar panel supplier will be able to advise you on this .